

COM[®] WAS-250-75/100/150 WAS-400-75/100/150

AUTOMATIC TAPING MACHINE

MAINTENANCE MANUAL

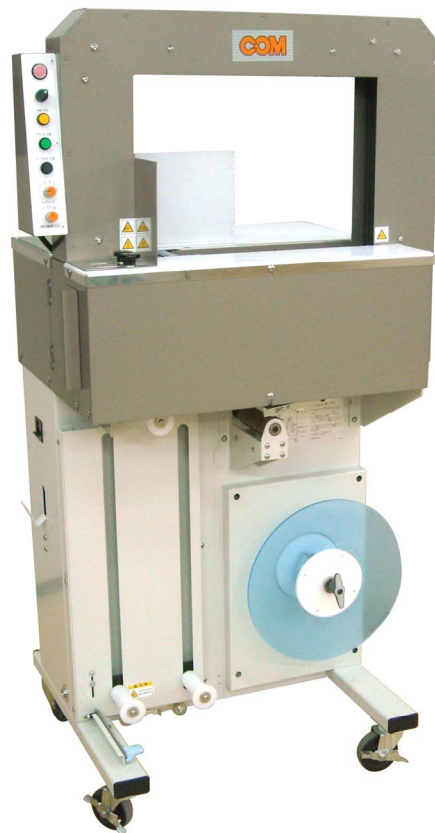

CONTENTS

Introduction	2
Name of each component.....	3
How machine works	4
Troubleshooting	5
Tape sealing failure	5
Sealed tape end adjustment failure	6
Tape cutting failure	7
Tape feeding failure	8
Tape tensioning failure	10
Machine start-up failure	11
Preparation for maintenance	13
Replacement of cutter clamp parts	15
Clamp plate (upper) spring replacement	18
Clamp plate (lower) spring replacement	19
Cutter blade replacement	21
Right clamp part replacement	22
Right clamp spring replacement	24
Heater assy part replacement.....	25
Heater plate assy replacement	27
Heater spring replacement	28
Rubber roller replacement	30
Slide plate spring replacement	31
Roller spring replacement.....	31

Introduction

This manual introduces instructions and explanation for replacement and adjustment which are usually practiced when changing major parts.

This manual also describes finding of causes of troubles based on the experienced troubles and problems. The cause of such troubles and the measures to be taken will be useful when operators/engineers operate check-up, adjustment, disassembly and reassembly of the machine.

Manufacturer
TAIYO SEIKI CO., LTD..



CAUTION

Do not fail to turn off the power switch when changing or adjusting any assy/part.
Very careful work is required as there is a risk of causing accidents and physical damages.
Make sure heater has been cooled down sufficiently as hot heater will cause burn when touching parts around the heater.
The manufacturer of this machine cannot be responsible for any mechanical and physical damages caused during operations.



WARNING

Check, adjustment, disassembly and reassembly of this machine must be operated by the experienced or authorized engineers/operators only. These works must be practiced after reading and understanding this manual thoroughly.

Name of each component

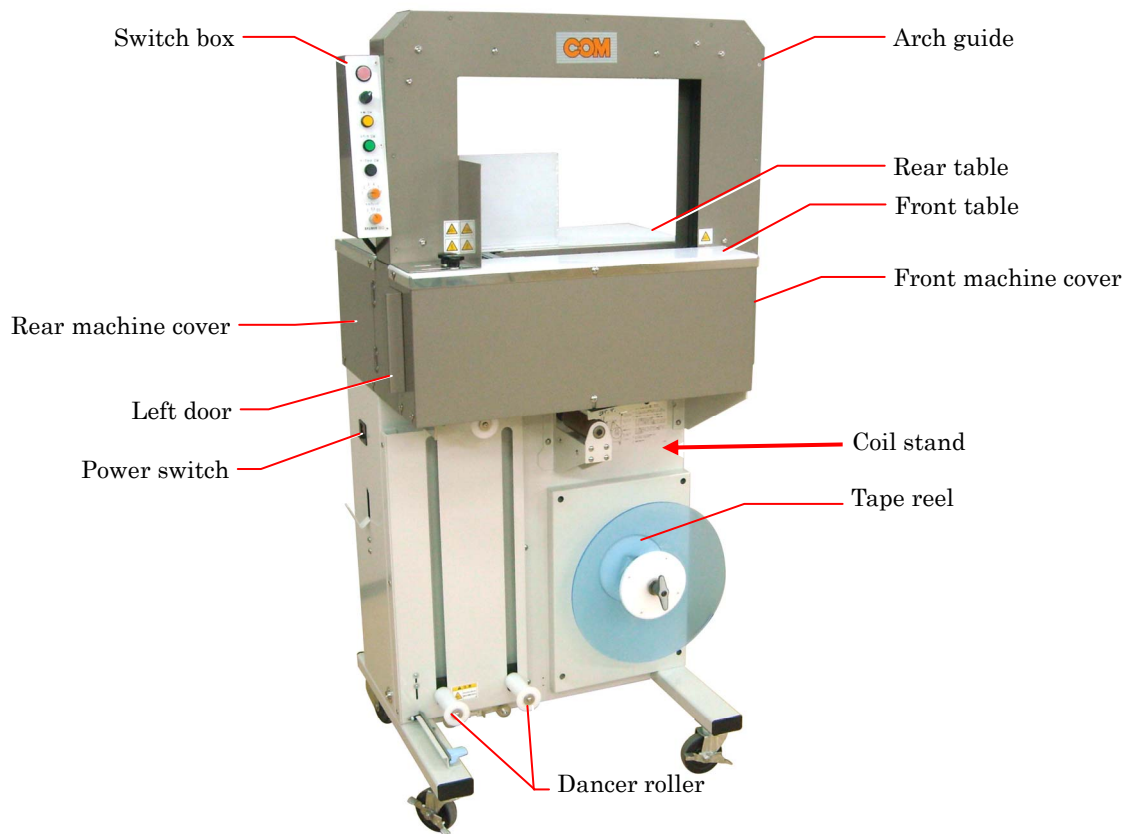

Front view of machine

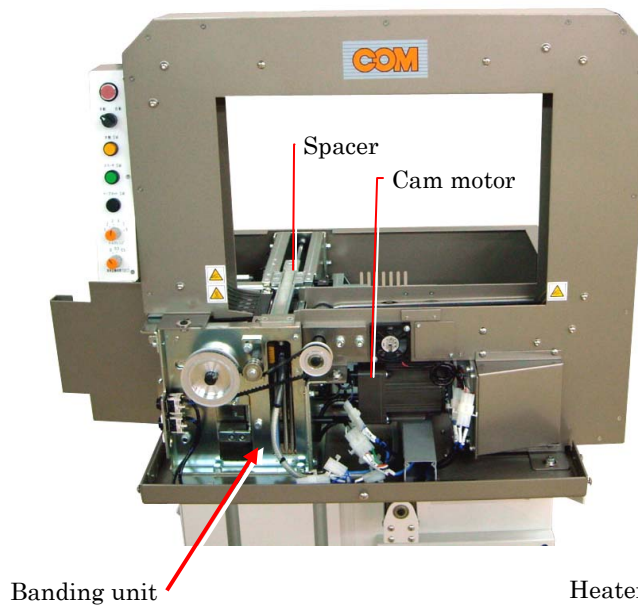

Rear view of machine

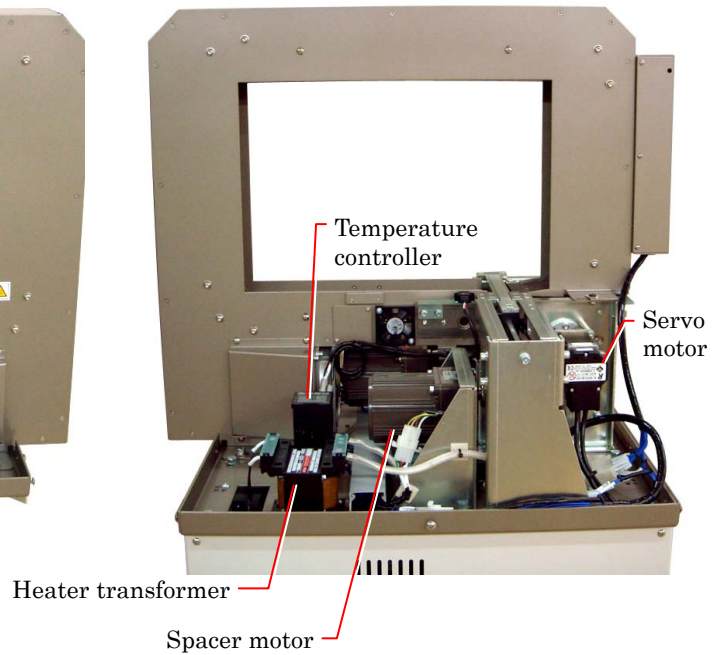

How machine works

The machine functions must be understood thoroughly so that troubleshooting can be operated safely.

WAS features unique functioning of banding and tape setting inside the arch guide.

Banding can be started by pressing the manual switch in the manual mode or by detecting a workpiece (product) in the machine. The tape is wound around the workpiece in the machine, then the tape is sealed and cut. This is one cycle of operation. When the workpiece is take out the tape is set inside the arch guide again, so that the next cycle of operation can be started. The phase when the tape has been set and is ready to run, is the home position (origin) of the machine.



Home position

Soon after a cycle of run is started, the clamp plate (upper) grips the tape head.

Then the servo motor runs and roller pulls the tape. When the tape is wound around the workpiece in the machine, the right clamp plate and the clamp plate (lower) grip the tape keeping the tape securely tensioned, the cutter cuts the tape, and the heater seals the tape. The spacer between the work and the tape will move back permitting the spacer to move back to its home position. The taping cycle is completed now.

When the finished workpiece is taken out the product sensor will be energized to run the roller for feeding the tape into the arch guide (now back to the home position).

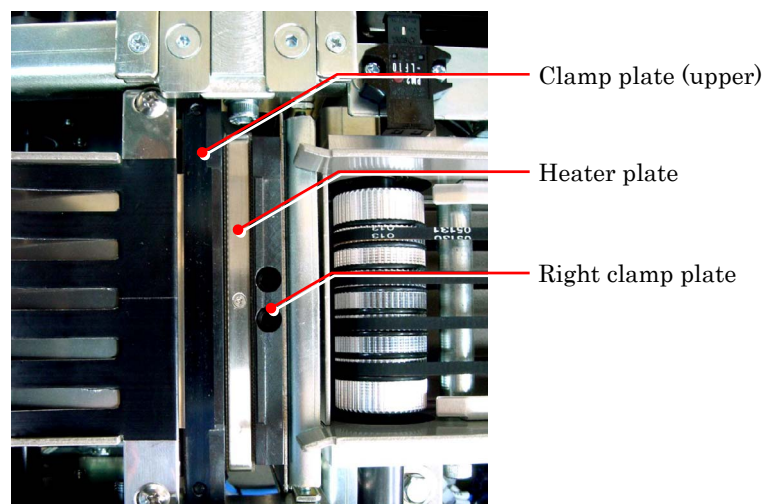

Banding assy

Troubleshooting

◆ Tape sealing failure

1. Temperature problem

REMEDY:

Adjust temperature by UP or DOWN key in the temperature controller.

This controller can be found at the right hand side when removing the rear table.

REF.:

Dismounting of rear table (P.13)

Temperature controller

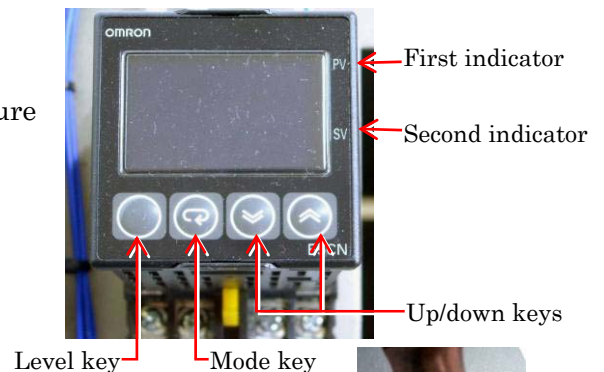

2. Heater temperature can not rise

- (1) [S.ERR] is displayed on the screen of the temperature controller.

CAUSE: Thermocouple damage

REMEDY: Heater plate assy replacement

REF.: Heater plate assy replacement (P.27)

- (2) [50°C] is displayed on the screen of the temperature controller or this indication is not constant.

CAUSE: Heater wire damage

REMEDY: Heater plate assy replacement

REF.: Heater plate assy replacement (P.27)

- (3) Sealing failure

CAUSE: Heater spring damage

REMEDY: Heater spring replacement

REF.: Heater spring replacement (P.28)

* If the sealed tape ends are not matching, the clamp plate is not adequately gripping the tape end. This causes no allowance of tape sealing area. Adjust the clamp plate function.

REF.: Sealed tape end adjustment failure (P. 6)

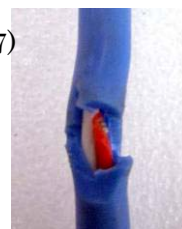
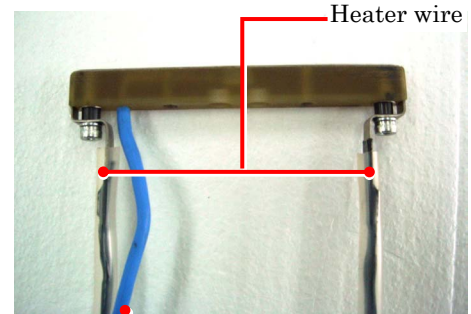

Thermocouple



Heater spring

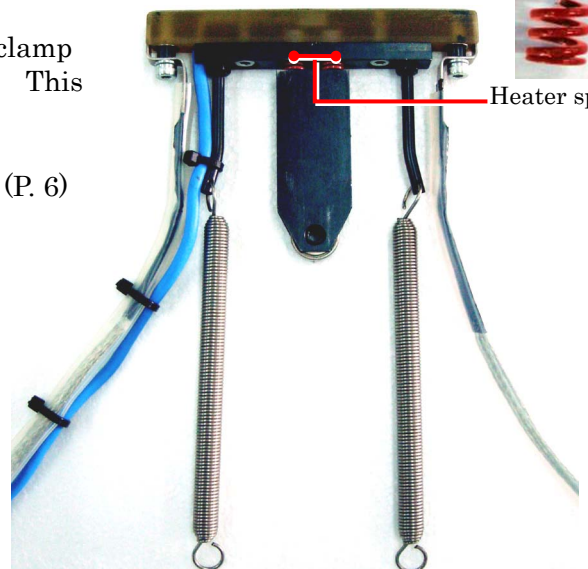

Heater assy

◆ Sealed tape end adjustment failure

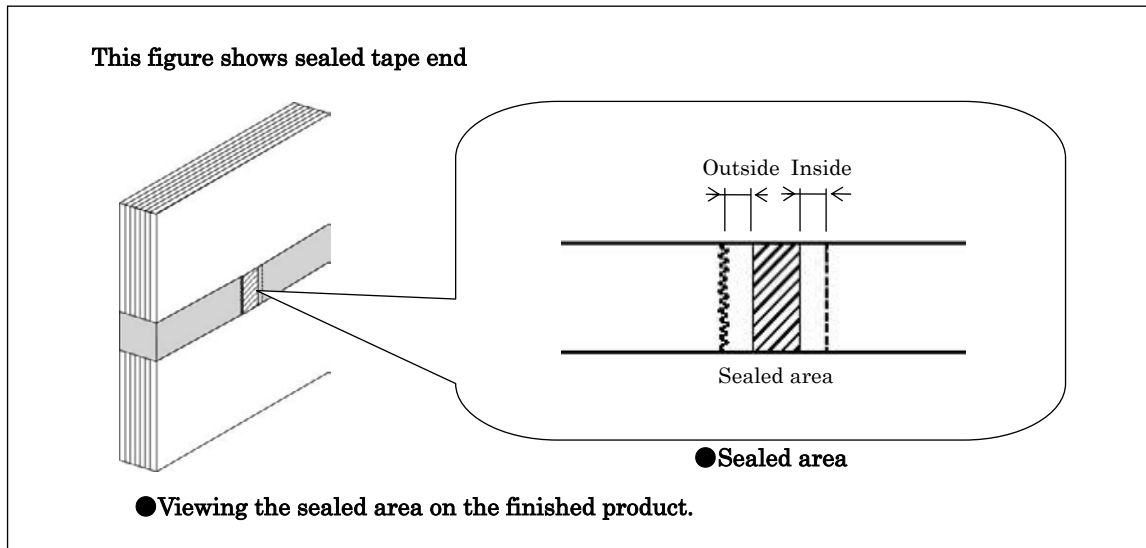

1. Outer end of sealed tape too short

CAUSE: Right clamp plate is not gripping tape securely. -> Right clamp spring damage.

REMEDY: Right clamp spring replacement

REF.: Right clamp spring replacement (P.24)

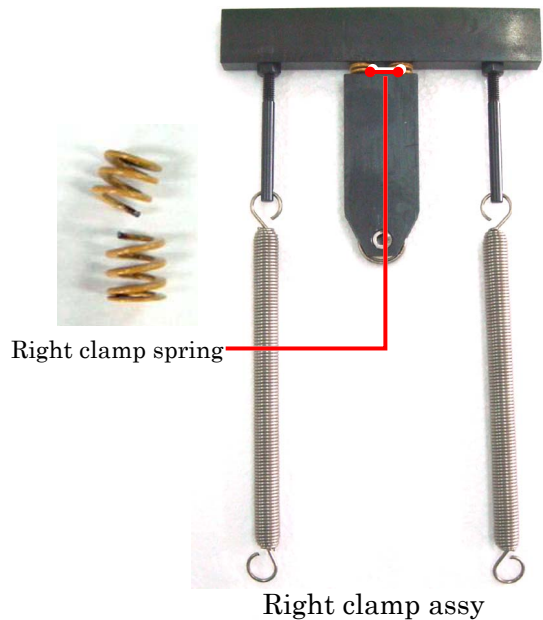

2. Inner end of sealed tape too short

CAUSE: Tape cannot be gripped tape on clamp plate.
-> Clamp plate (upper) spring damage.

REMEDY: Clamp plate (upper) spring replacement

REF.: Clamp plate (upper) spring replacement (P.18)

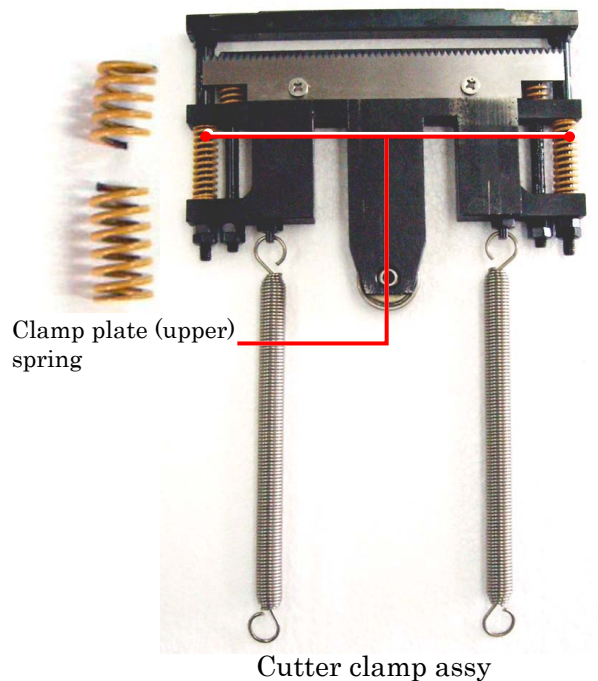

◆ **Tape cutting failure**

Tape cannot be cut or cutting is not smooth

CAUSE(1): Right clamp spring or clamp plate (lower) spring damage.

REMEDY: Right clamp spring replacement or clamp plate (lower) spring replacement

REF.: Right clamp spring replacement (P.24)
Clamp plate (lower) spring replacement (P.19)

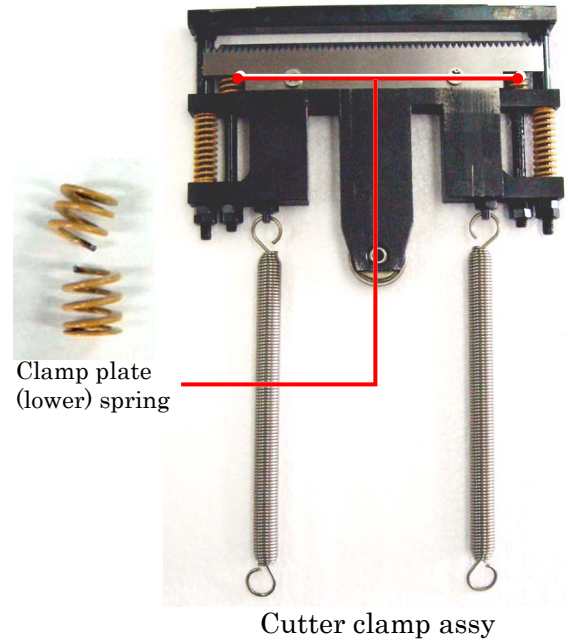
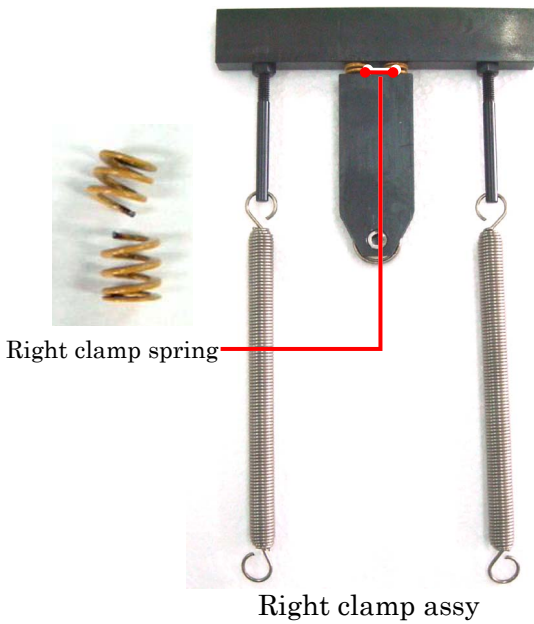

CAUSE(2): Cutter blade damage.

REMEDY: Cutter blade replacement

REF.: Cutter blade replacement (P. 21)

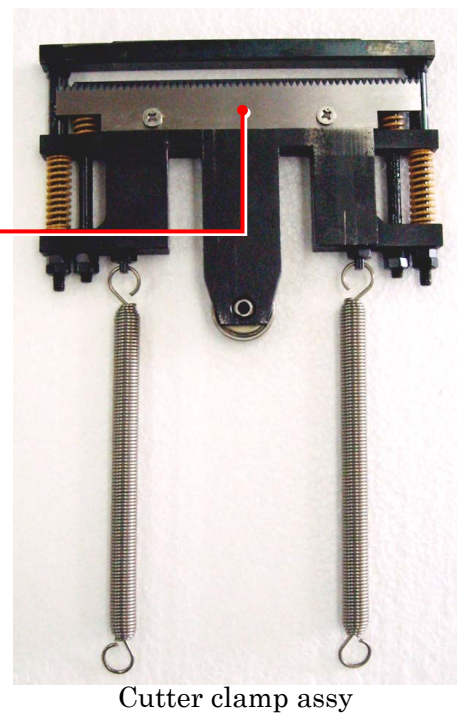
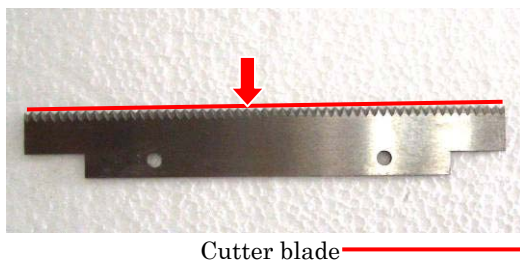

◆ **Tape feeding failure**

Tape is jammed at the rubber roller

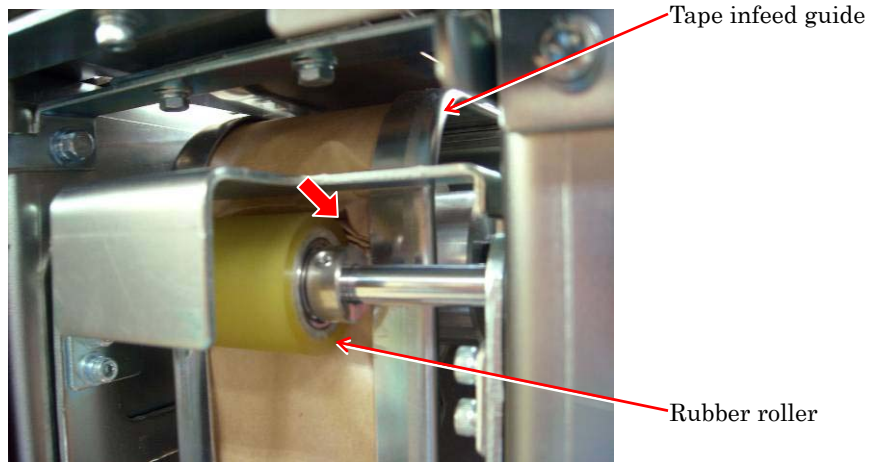

CAUSE(1): A cut piece of the adhesive tape which is used to fix the tape head of every new tape roll is preventing smooth feeding of the tape.

* If the tape becomes a state of fan-folding at the rubber roller, there is possibility that the tape infeed guide or clamp plate guide has a sticky material.

REMEDY: Remove such a sticky material using a metal rule. Then clean the surface with alcohol or lacquer thinner.

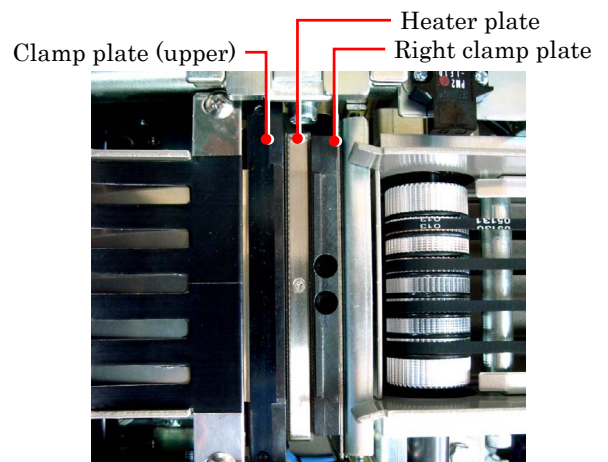

Problem caused by a piece of adhesive tape:

Every new roll of tape has a piece of adhesive tape to fix the tape head.

Cut about 60 cm of the tape to be used before setting it into the machine.

If not, this piece of adhesive tape will be adhered to the rubber roller and inner part of the machine causing jamming of the tape.

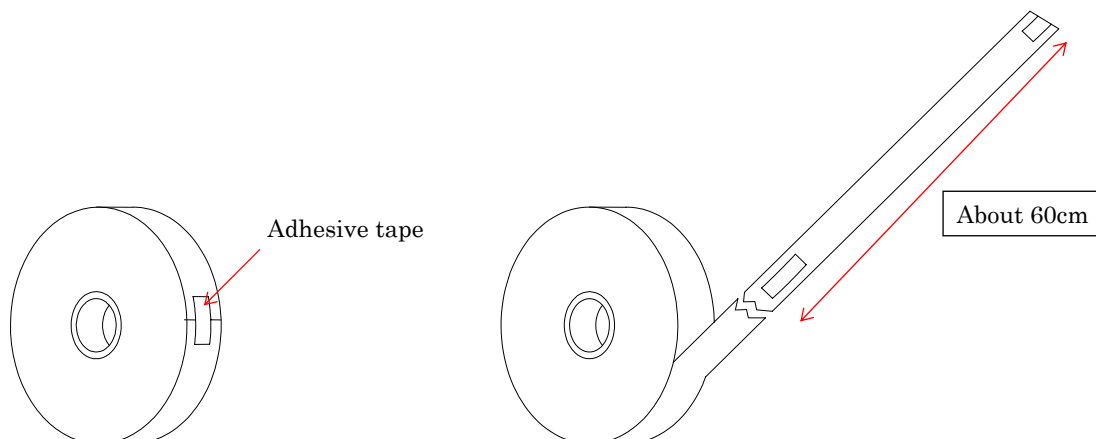

CAUSE(2): Wear on rubber roller causing meandering of tape.

REMEDY: Rubber roller replacement

REF.: Rubber roller replacement (P.30)



Rubber roller

CAUSE(3): Slide plate spring damage. The clamp plate, heater plate, and right clamp plate cannot return to their home positions causing that tape feeding is prevented.

REMEDY: Slide plate spring replacement

REF.: Slide plate spring replacement (P.31)

When tape feeding is in normal conditions, the clamp plate, heater and right clamp plate are placed down to their bottom positions because of the slide plate spring function. If the slide plate spring is damaged, these parts cannot be placed down causing prevention of tape feeding.

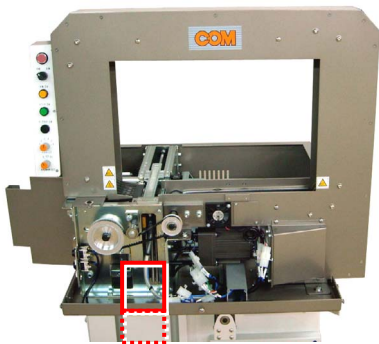

Front view of machine

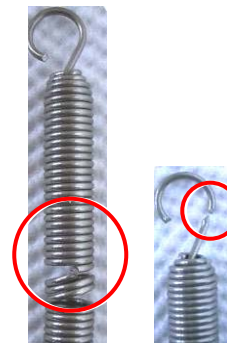

Slide plate spring

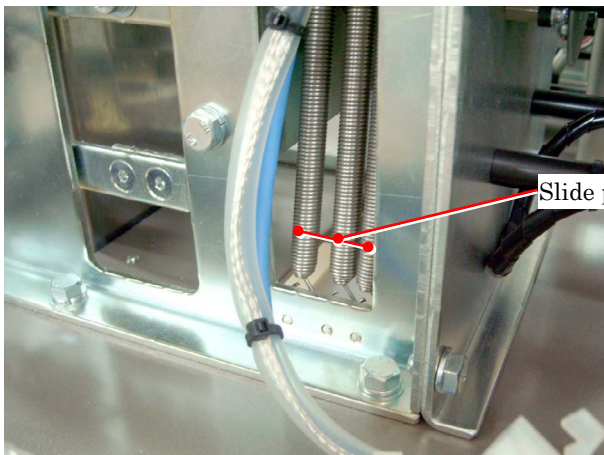

Slide plate springs

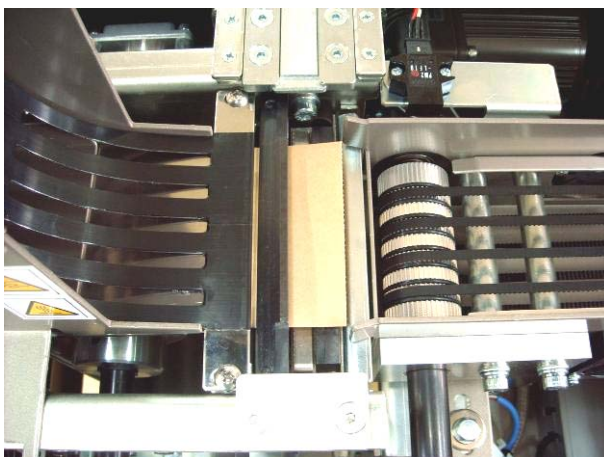
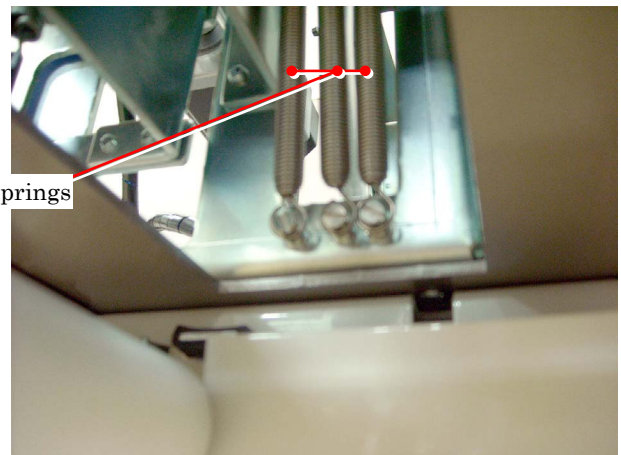

Feeding fair

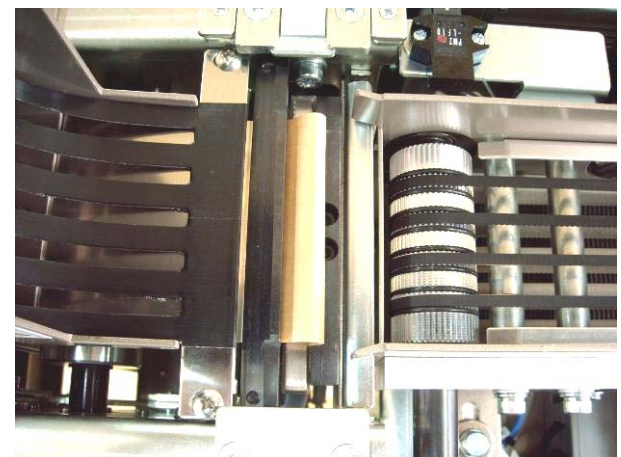

Feeding failure

◆ **Tape tensioning failure**

Tape tensioning is too low or no tensioning

CAUSE(1): Tape meandering due to wear of rubber roller.

REMEDY: Rubber roller replacement

REF.: Rubber roller replacement (P.30)

CAUSE(2): Roller spring damage

REMEDY: Roller spring replacement

REF.: Roller spring replacement (P.31)



Rubber roller

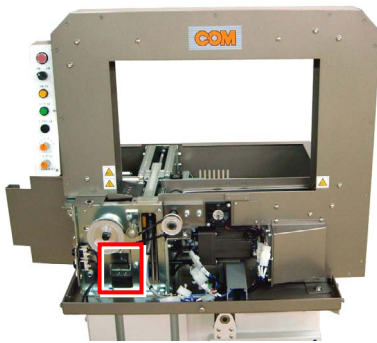

Front view of machine



Roller spring

◆ Machine start-up failure

1. Banding cannot be operated when pressing the manual switch to on in the manual mode or when the product in the machine cannot be detected in the automatic mode.

CAUSE: The machine is not in the home position or the dancer roller is at the bottom position even when the machine is in the home position.

REMEDY: Press the tape cut switch.

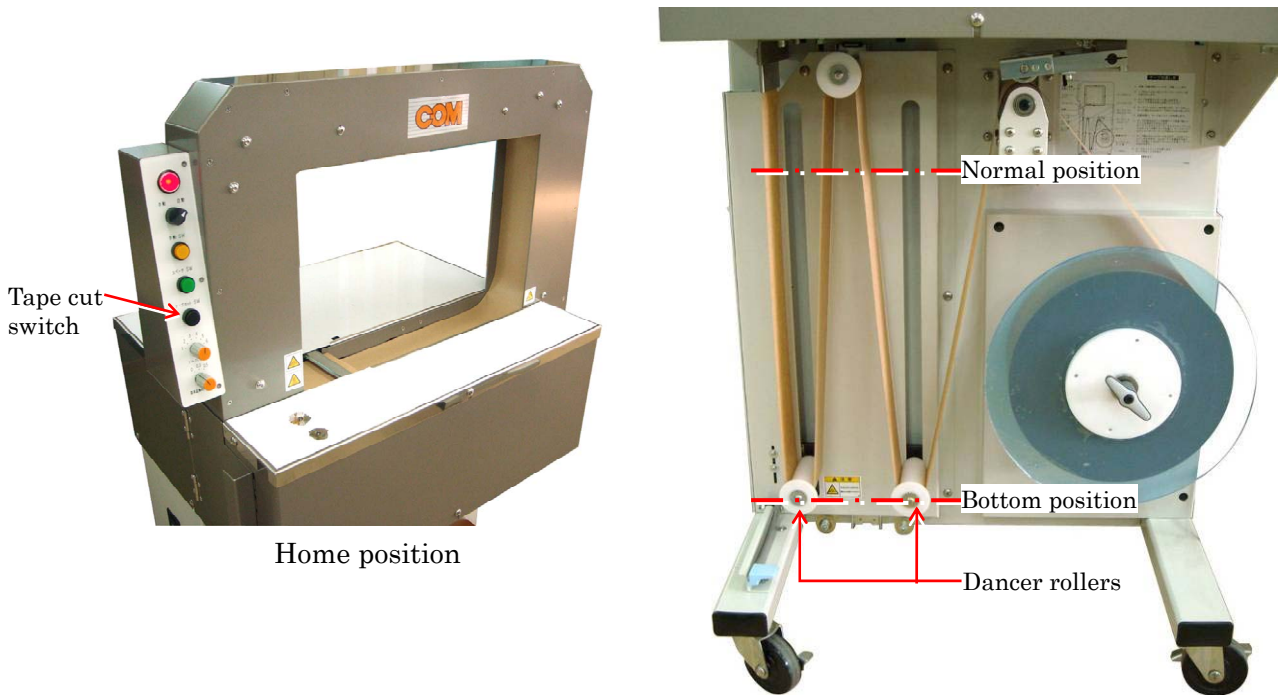

2. The RUN lamp is flickering periodically.

CAUSE: The machine is detecting a warning condition.

REMEDY: Check for the alarming condition and press the tape cut switch.

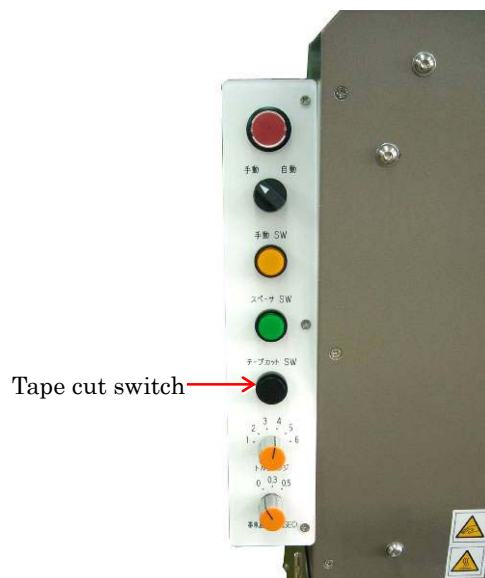

Alarming condition

Frequency of flickering	Alarm signal	Details
Once	Heater start-up alarm	Heater temperature cannot rise to the preset level after the power is supplied.
Two times	Heater temperature alarm	Heater cannot keep the preset level.
Three times	Cam motor alarm	Cam motor is not fair.
Four times	Tape reel motor alarm	Tape reel motor is not fair.
	Tape brake alarm	Tape brake is not fair. *There may be a case that this signal is outputted when the tape is runout completely. Set a new tape reel after pressing the tape cut switch for clearing this alarm signal.
Five times	Roller servo motor alarm	Servo motor is not fair.
Six times	Spacer motor alarm	Spacer motor is not fair.

* These alarm signals will be released by pressing the tape cut switch. If the situation cannot be improved, please contact your local agent.

* Intermittent flickering after turning the power switch on is showing the state that the machine is preparing for start-up. The machine will be ready to start in 20-60 seconds after this state.

Preparation for maintenance

1. Dismounting of front table

Remove 3 screws shown with arrows, and lift the front table.

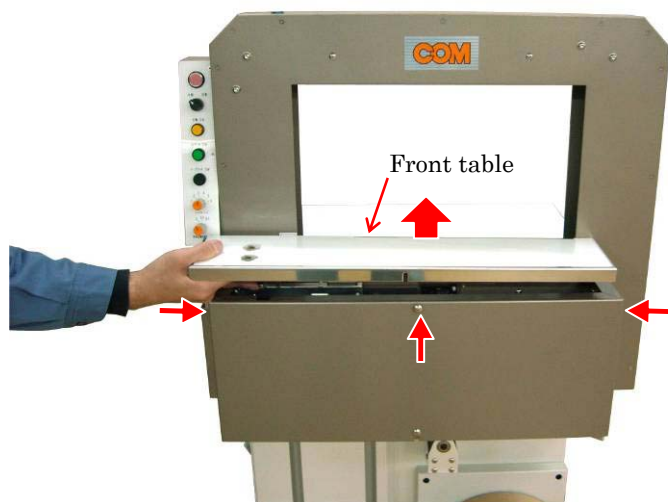

Front view of machine

2. Dismounting of rear table

Remove 3 screws shown with arrows, and lift the rear table.

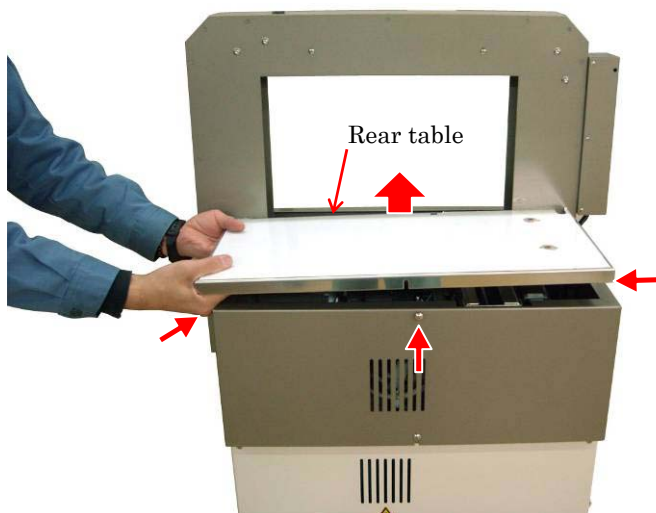

Rear view of machine

3. Dismounting of front machine cover

(1) Disconnect the lead wire (X11) of the magnet catch with built in switch.

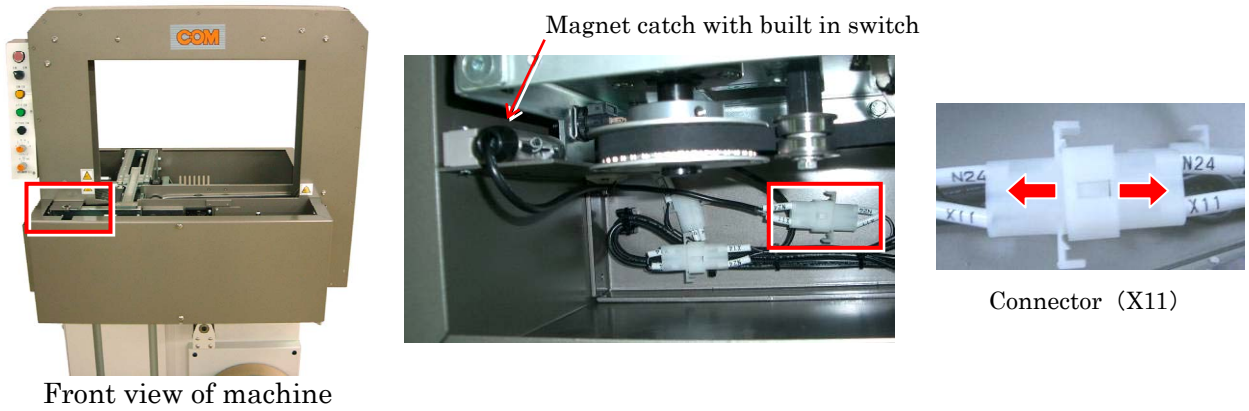

(2) Loosen 5 screws shown with arrows. Open the left door and lift the machine cover.

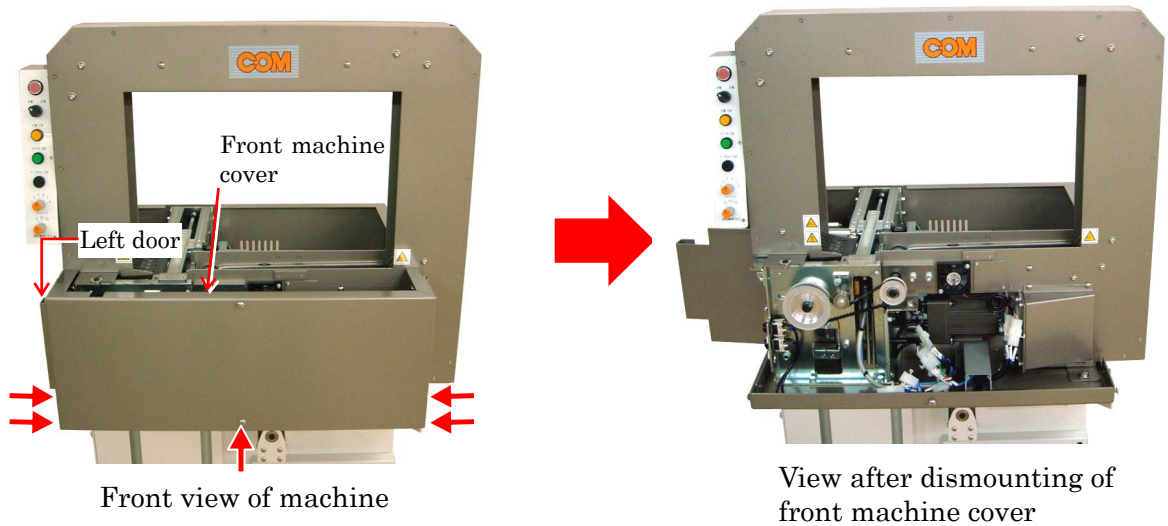

4. Dismounting of rear machine cover

Loosen 5 screws shown with arrows. Open the left door and lift the machine cover.

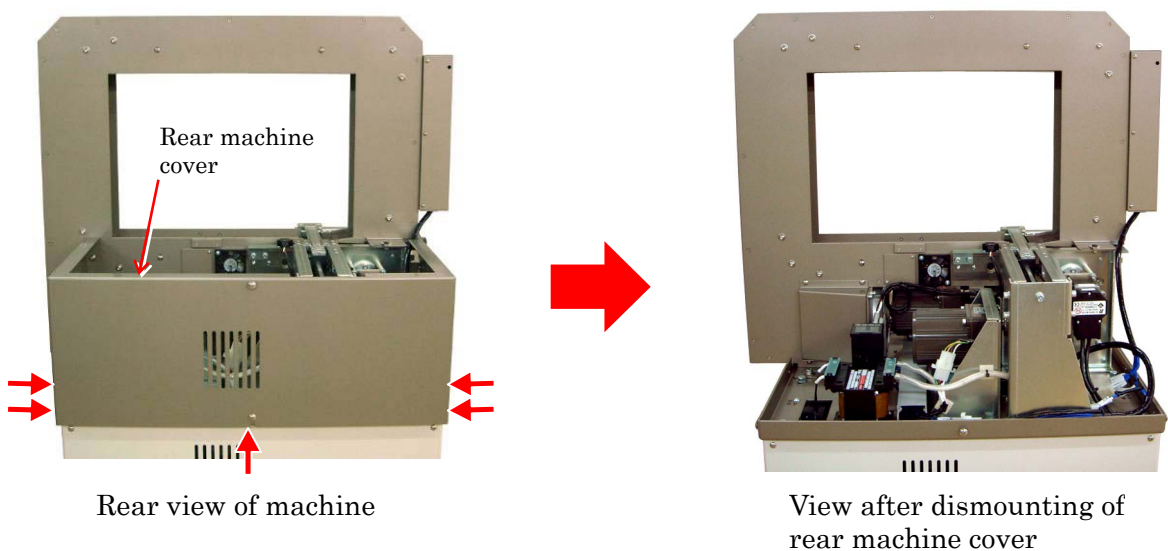

Replacement of cutter clamp parts

When changing the cutter clamp parts, dismantle the cutter clamp assy from the banding unit.

Dismounting of cutter clamp assy

- 1) Dismount the front table, rear table, front machine cover and rear machine cover.
REF. Preparation for maintenance (P.13)
- 2) Remove two bolts shown with arrows.

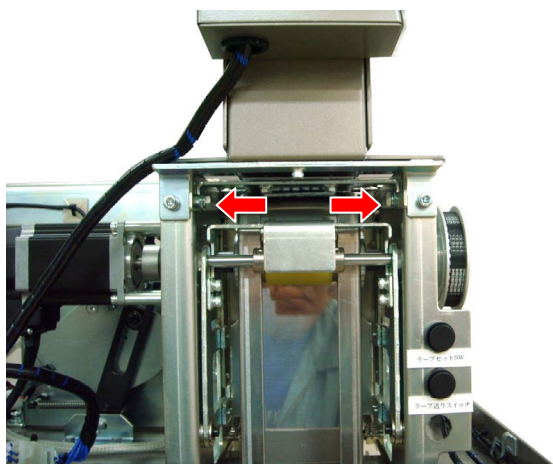

Left side of machine

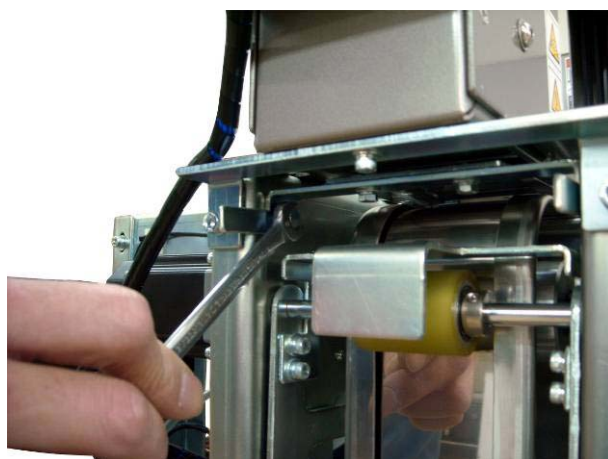

- 3) Remove the tape guide (upper).

Tape guide (upper)

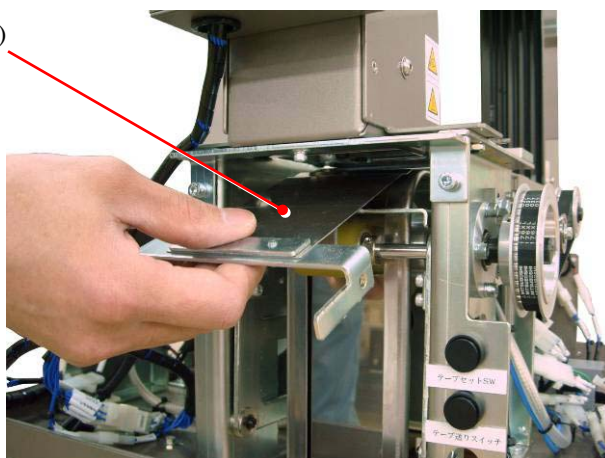

- 4) Remove two bolts shown with arrows and then dismount the slide guide.

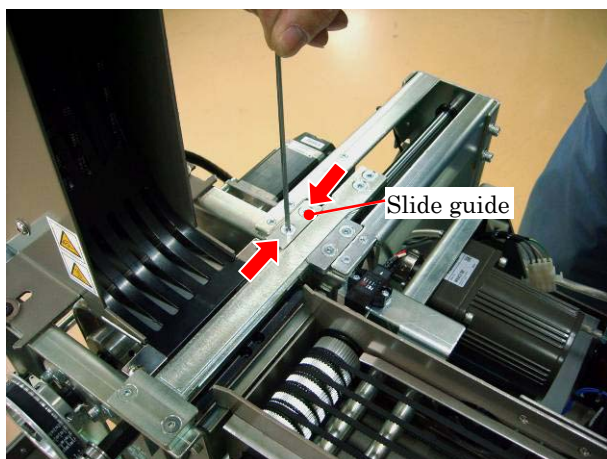

5) Remove two bolts shown with arrows and then dismount the spacer.

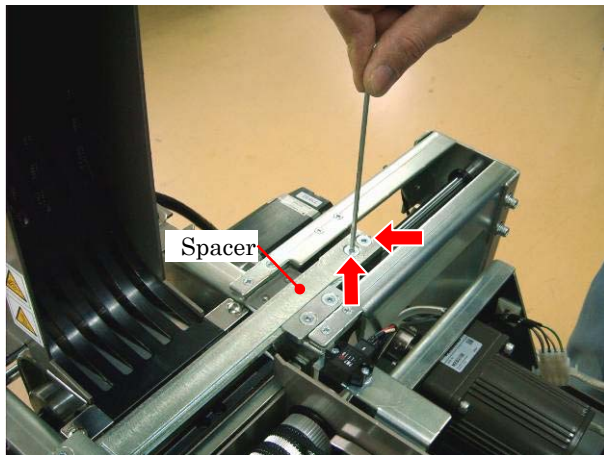

6) Remove two bolts shown with arrows and then dismount the spacer stopper.

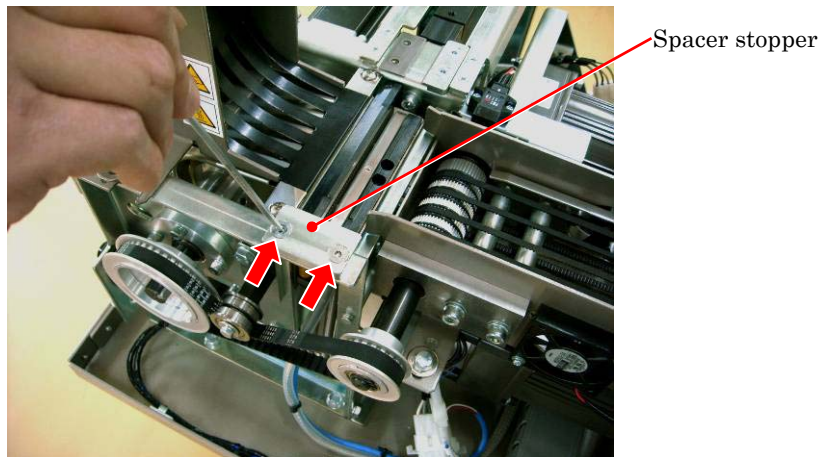

7) Disconnect two slide plate springs shown with an arrow from the spring support. These springs are located below the side frames (front and rear).

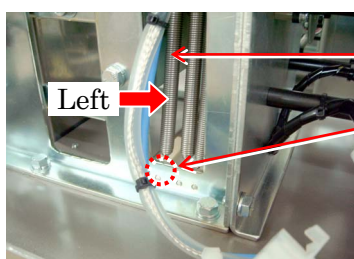
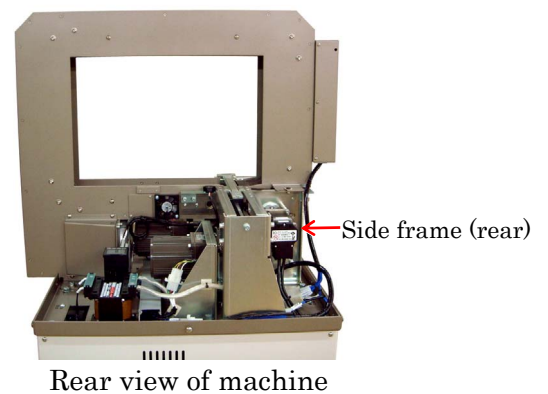
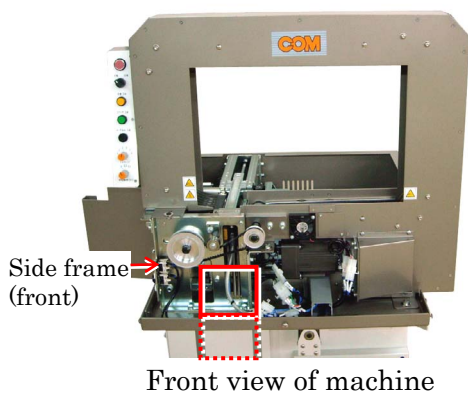

Slide plate springs

Spring supports

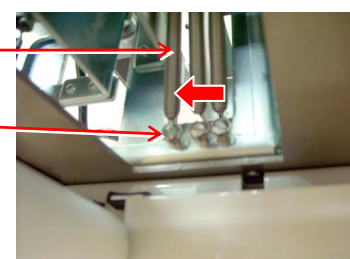

8) Now pull up the cutter clamp assy as shown in the photo.

⚠ Carefully handle this assembly as the cutter blade may damage your fingers.

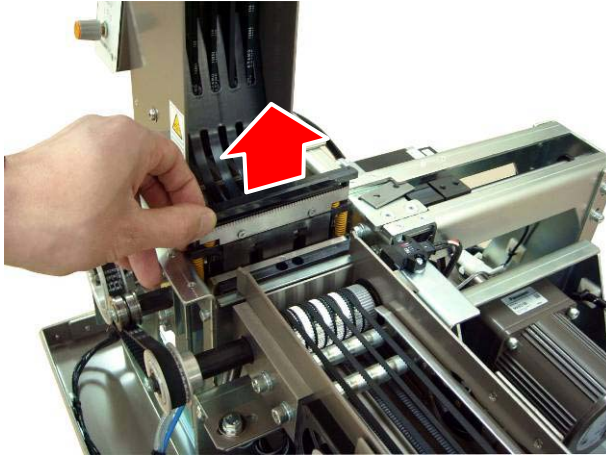

Cutter clamp assy

* Reverse the procedures which are used to dismount this cutter clamp assy. Special cares must be taken when remounting the tape guide (upper) --.

Position when remounting tape guide (upper)

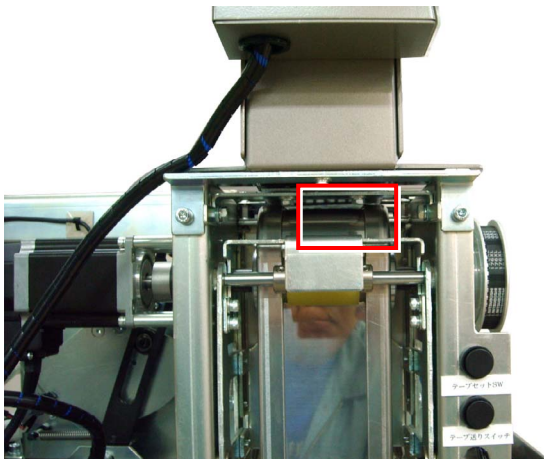

Left side view of machine

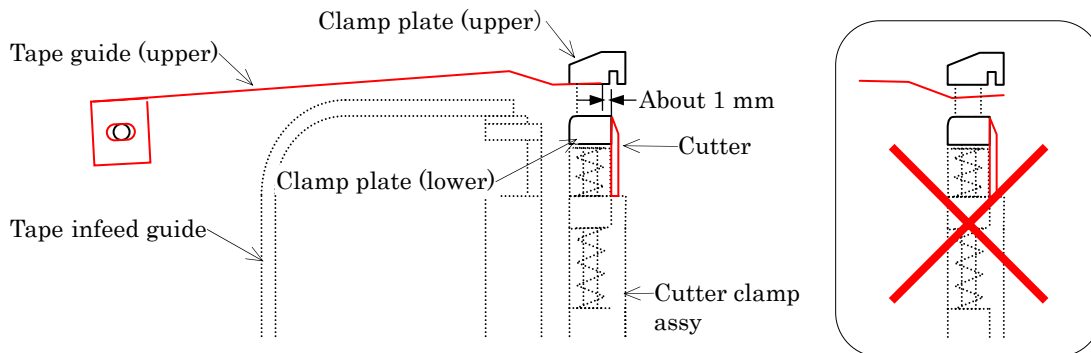
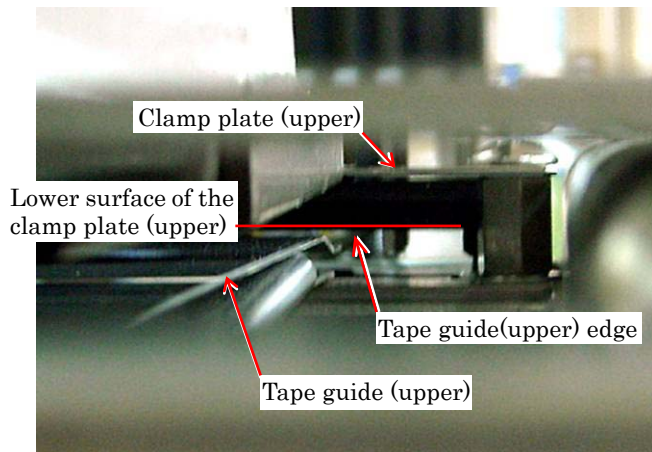

The tape guide (upper) should be mounted after inserting the edge of this guide between the clamp plate (upper) and clamp plate (lower). At this time of mounting, adjust the tape guide (upper) allowing that the tape guide(upper) edge contacts the lower surface of the clamp plate (upper). There must be a gap of about 1 mm between the tape guide (upper) edge and the cutter blade. If the cutter blade position exceeds this allowance, the cutter blade will be damaged by tape guide edge.

* This allowance is a suggested gap only. Do not fail to adjust it after mounting all parts.

◆ Clamp plate (upper) spring replacement

When changing the clamp plate (upper) spring, dismantle the cutter clamp assy first.
 REF.: Dismounting of cutter clamp assy (P.15)

- 1) Disconnect the slide plate spring from the cutter clamp assy. Remove two nuts shown with arrows.

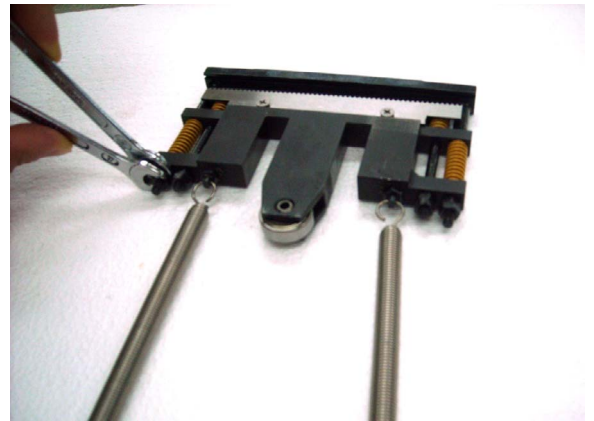
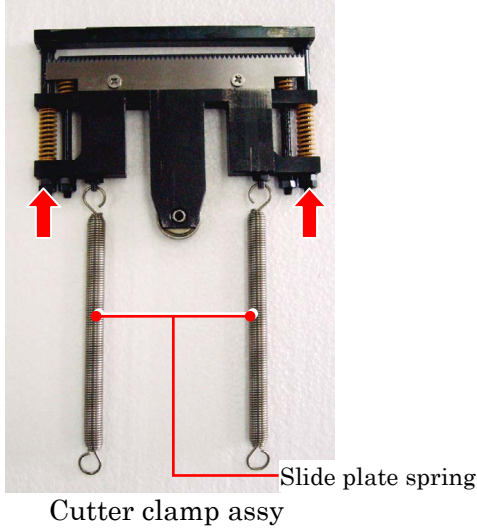

- 2) Clamp plate (upper) spring can be replaced easily after the clamp plate (upper) is pulled out toward the arrowed direction.

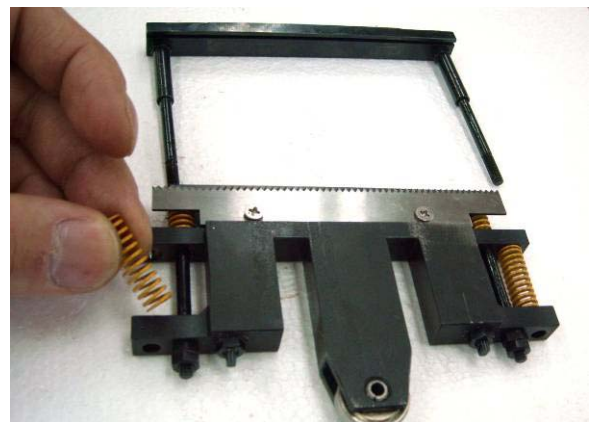
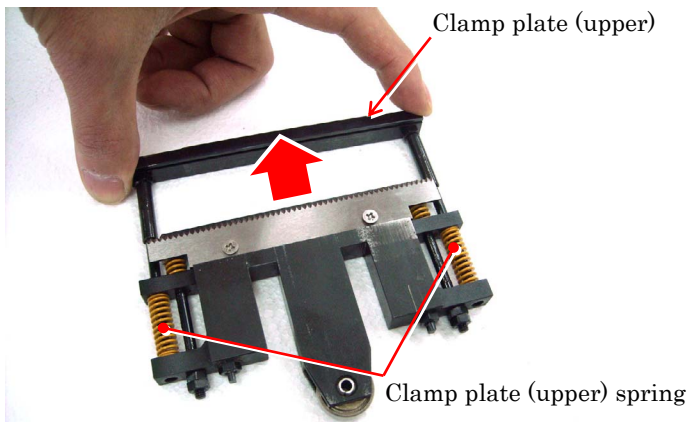

* Do not fail to remount this assy in the way it was fixed.
 When mounting the clamp plate (upper to the slide plate), the clamp plate (upper) spring must not be pressed (free compression). Do not allow this spring pressed.

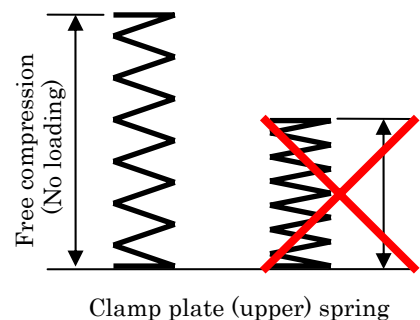
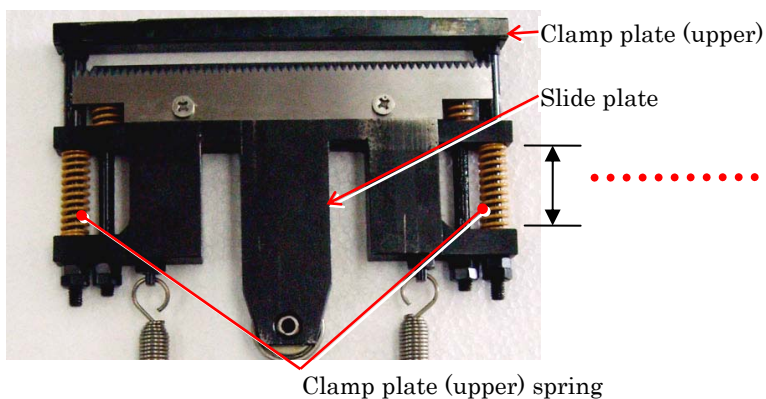

◆ Clamp plate (lower) spring replacement

When changing the clamp plate (lower) spring, dismount the cutter clamp assy first.
REF.: Dismounting of cutter clamp assy (P.15)

- 1) Remove two slide plate springs from the cutter clamp assy, and then remove two nuts shown with arrows.

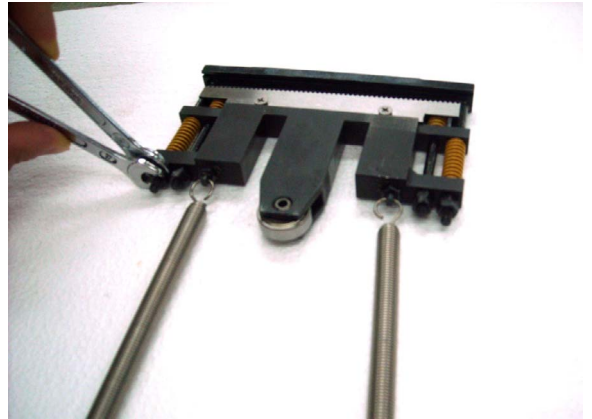
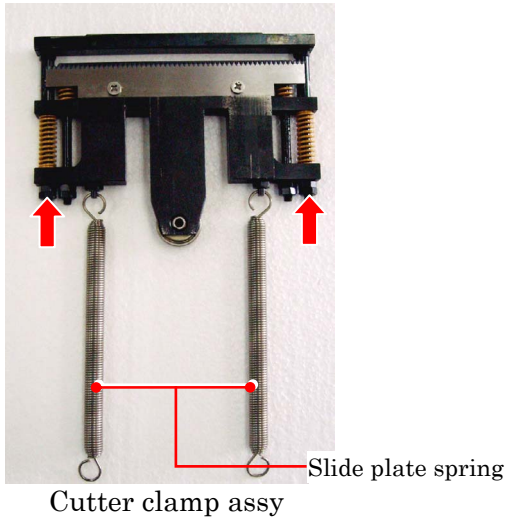

- 2) After dismounting the clamp plate (upper), remove two nuts shown with arrows.

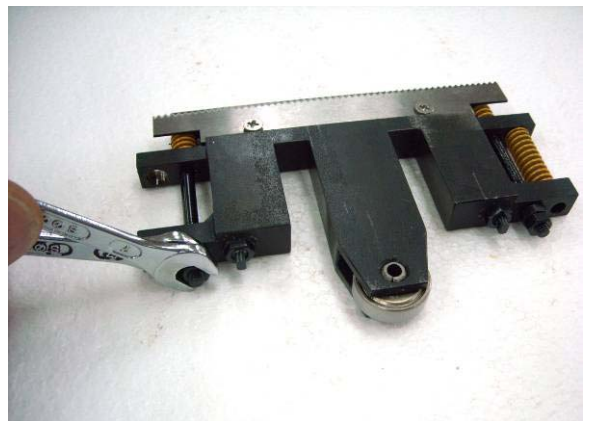
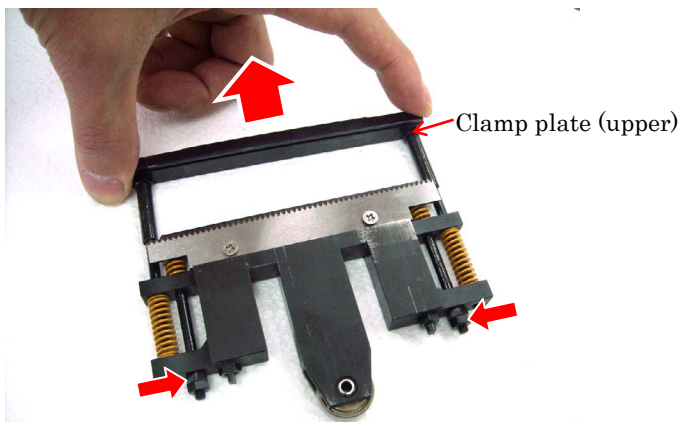

- 3) The clamp plate (lower) spring can be replaced after dismounting the clamp plate (lower) toward the arrowed direction.

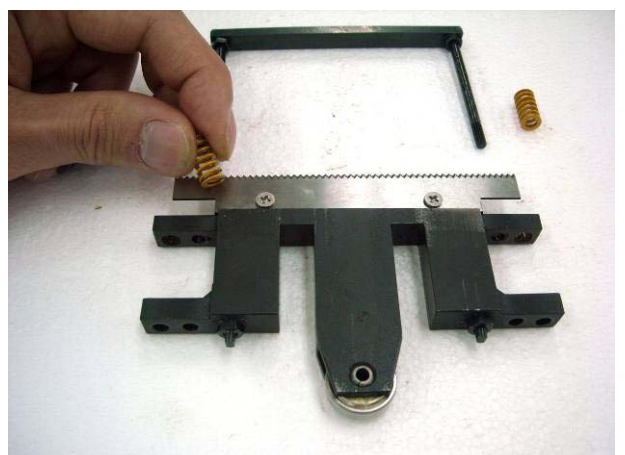
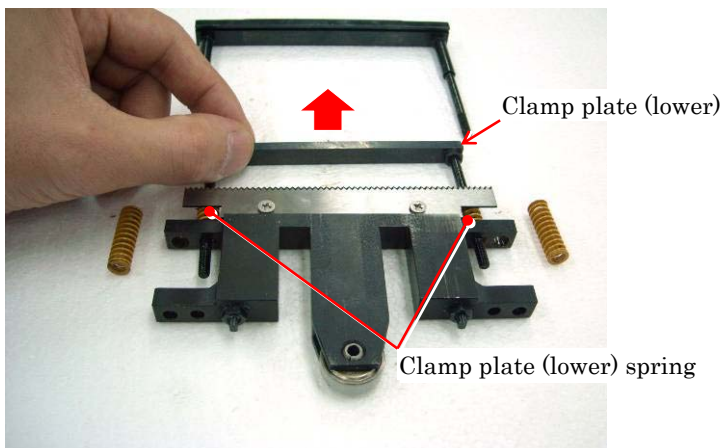

* Remount this assembly as it was fixed.

When fixing the clamp plate (lower) to the slide plate, there must be a gap of 5 mm between the lower face of the clamp plate (lower) and the upper face of the slide plate.

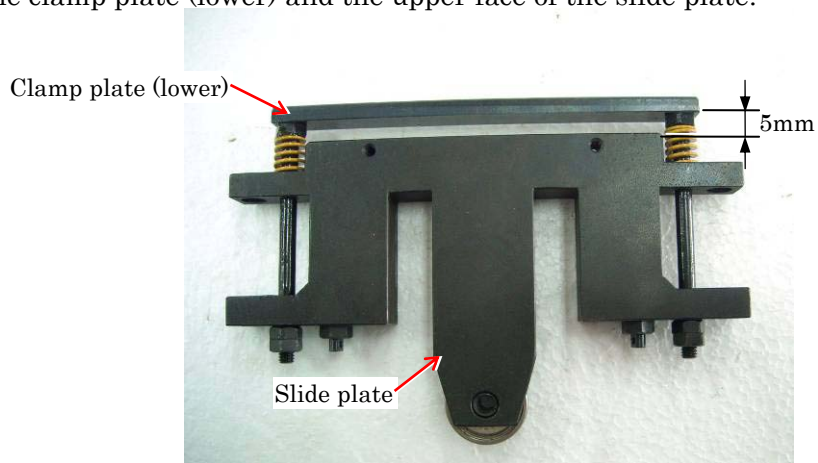

◆ Cutter blade replacement

When changing the cutter blade, dismount the cutter clamp assy first.

REF.: Dismounting of cutter clamp assy (P.15)

Remove two screws shown with arrows for dismounting.

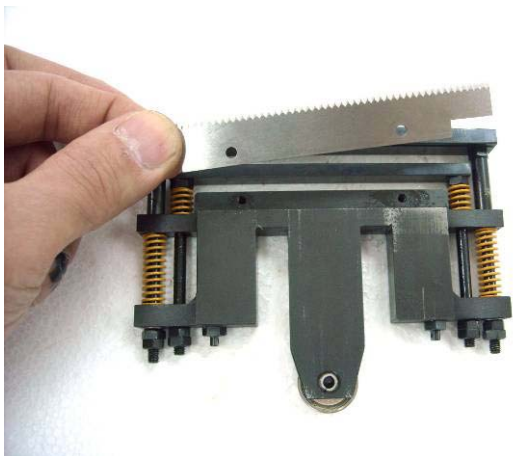
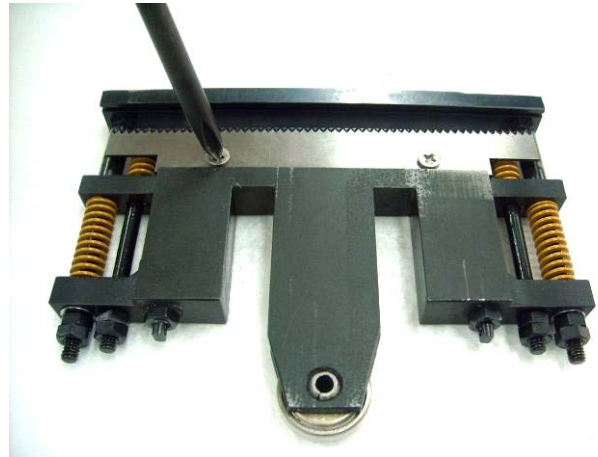
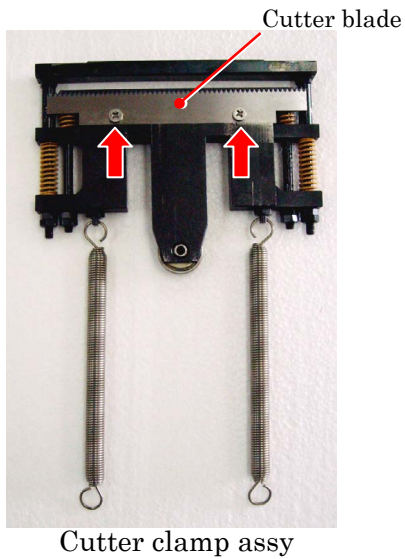

⚠ Carefully handle the blade so that your fingers cannot be damaged.

* Securely fix the blade as it was fixed.

Right clamp part replacement

When changing the right clamp part, dismantle the right clamp assy from the banding unit.

Dismounting of right clamp assy

- 1) Dismount the front and rear tables.
REF. Preparation for maintenance (P.13)
- 2) Remove two bolts shown with arrows and then slide the spacer toward the arrowed direction.

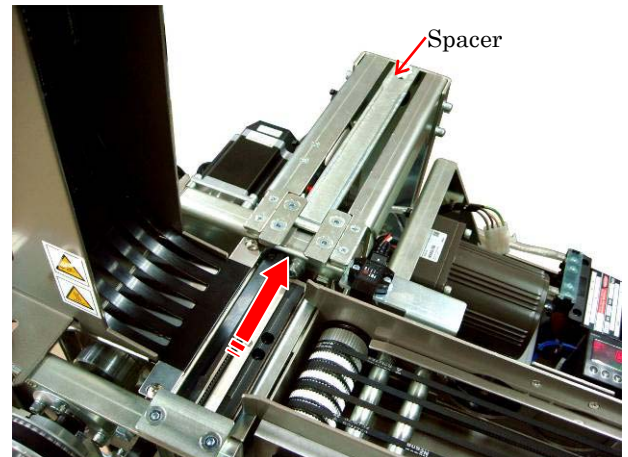
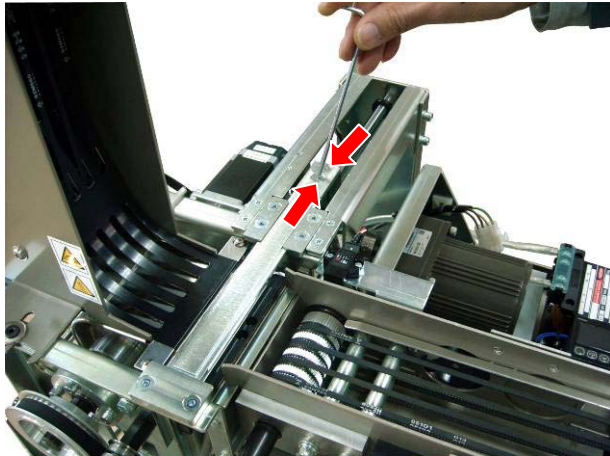

- 3) Disconnect two slide plate springs from the spring support. These are located below the side frames (front and rear).

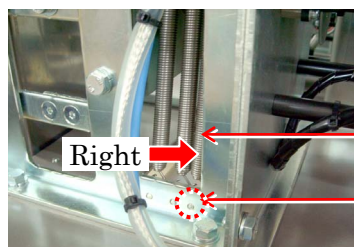
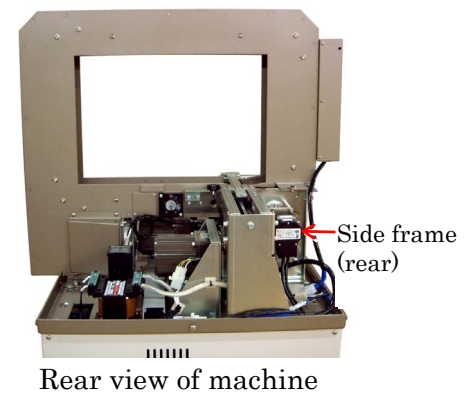
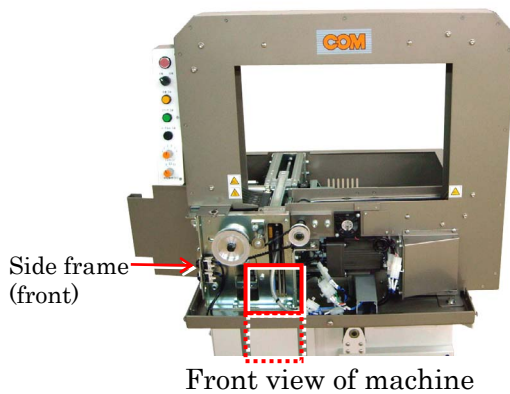

Slide plate springs

Spring supports

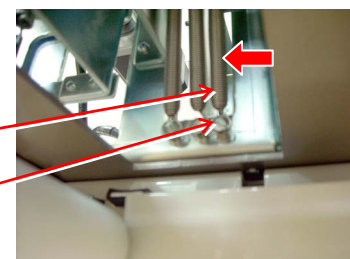

- 4) Grip the right clamp plate using a tool (like long nose pliers) and pull up this plate toward the arrowed direction, so that the right clamp assy can be disconnected easily.
* Do not allow the part damaged.

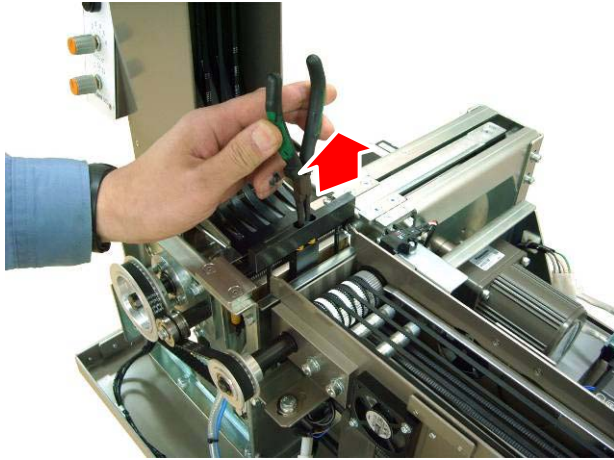

Right clamp assy

- * Remount the right clamp assy as it was fixed.

◆ Right clamp spring replacement

When changing the right clamp spring, dismount the right clamp assy from the banding unit.

REF.: Dismounting of right clamp assy (P. 22)

- 1) Loosen two set screws (locking screws) shown with arrows A, which are located at both sides of the slide plate.



Right clamp assy

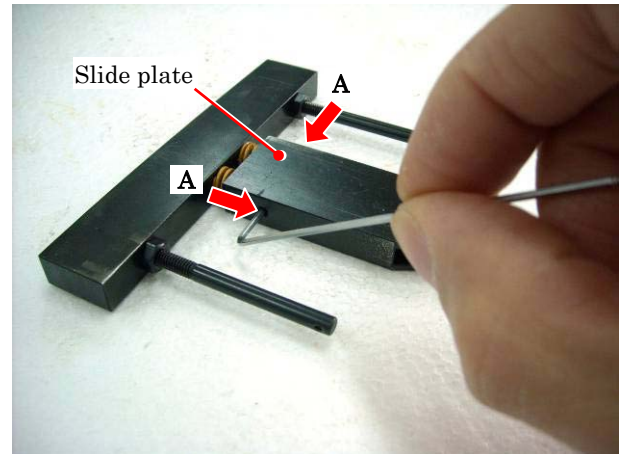

- 2) Remove two bolts shown with B from the slide plate, dismount the right clamp plate and then replace the right clamp spring.

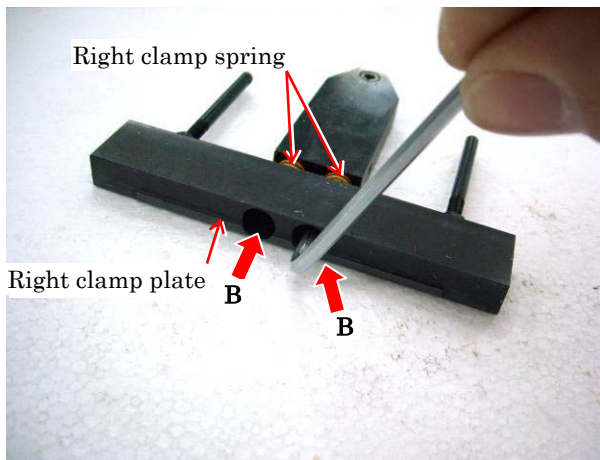

* Do not fail to remount the plate as it was fixed.

When remounting the right clamp plate using bolts B to the slide plate, there must be 3 mm between the right clamp plate lower face and slide plate upper surface. Then tighten set screws A.

When remounting the right clamp assy, make sure that the face to be contacted to the banding unit is correct.

The convexed area must be at left when viewing the machine from front.

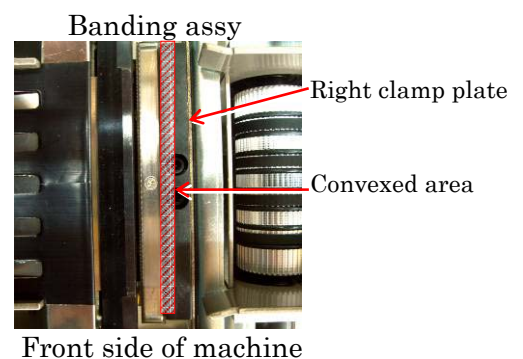
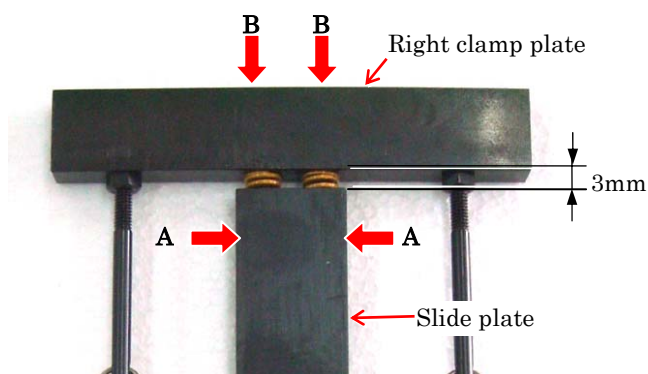

Heater assy part replacement

 Make sure the power switch is turned off when changing heater assy parts.
Make sure this assy has been cooled down so that your fingers cannot suffer from burning.

When changing the heater part, dismantle the heater assy from the banding unit.

Dismounting of heater assy

- 1) Dismount the front table, rear table, front machine cover and rear machine cover.
REF.: Preparation for maintenance (P. 13)
- 2) Loosen two screws shown with arrows and disconnect the heater wires from the heater transformer.

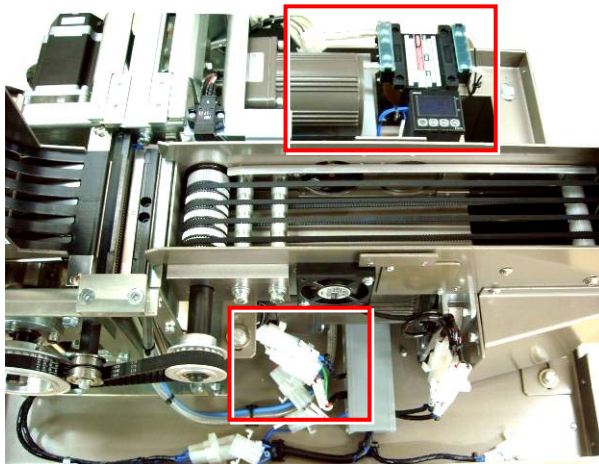

Front view of machine

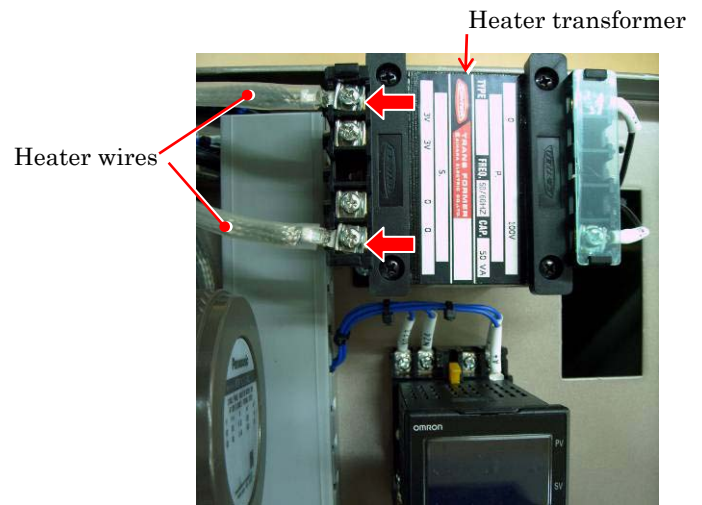

- 3) Disconnect the thermocouple connectors (A+, A-).

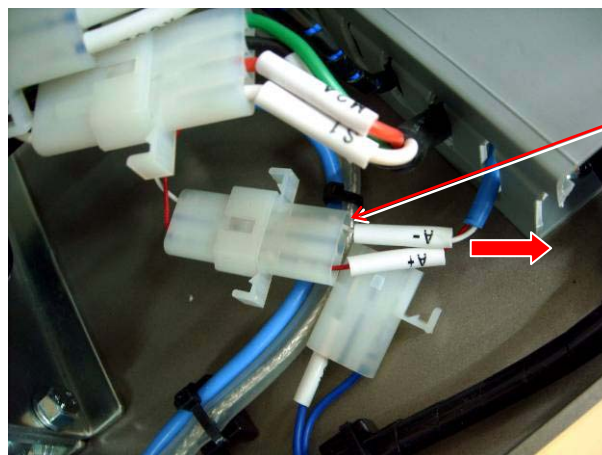

Thermocouple connector

* Plastic band for binding heater wires, thermocouple wires, etc. can be cut away using tools.
Do not allow wires to be damaged.

- 4) Disconnect two slide plate springs from the spring support. These are located below the side frames (front and rear).

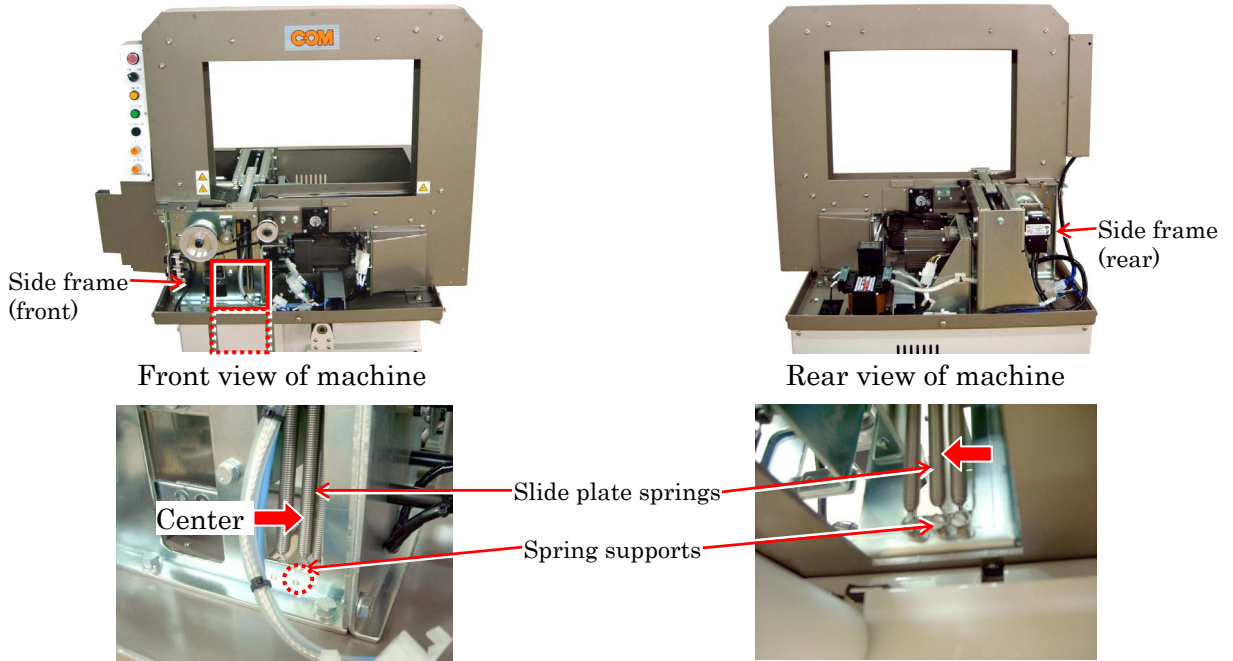

- 5) You will find the heater wire in this assy. Lift it by hand toward "A" shown with the arrow. When the heater assy is lifted up, pull out the heater assy toward "B" shown with the other arrow.
 * Carefully dismount the heater assy because it is connected with heater wires and thermocouple.

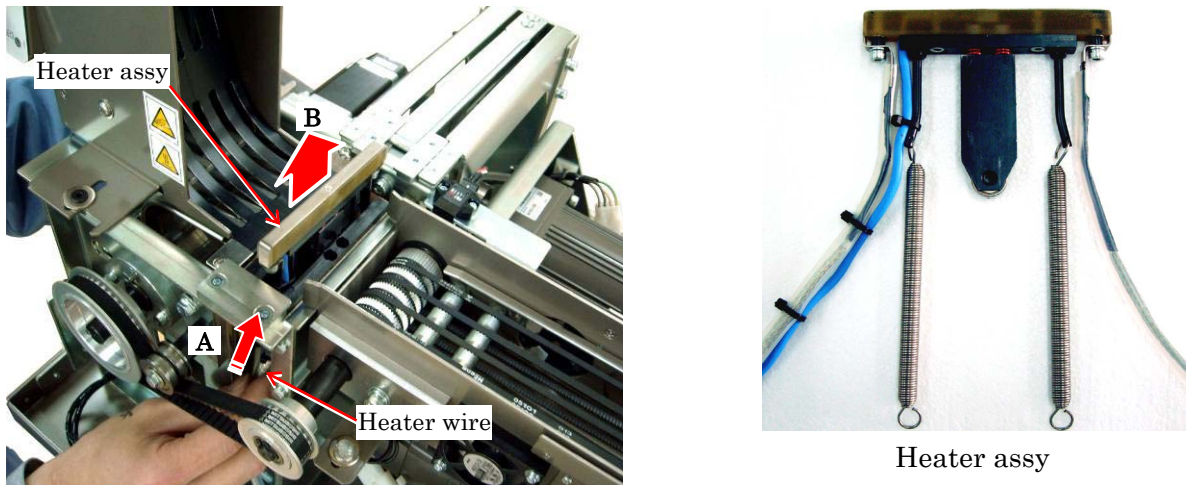

- * Heater assy must be remounted to the banding unit as it was fixed.

◆ Heater plate assy replacement

Dismount the heater assy from the banding unit when replacing the heater plate assy.

REF.: Dismounting of heater assy (P. 25)

- 1) Loosen the two bolts shown with arrows which are used to fix the heater plate assy.

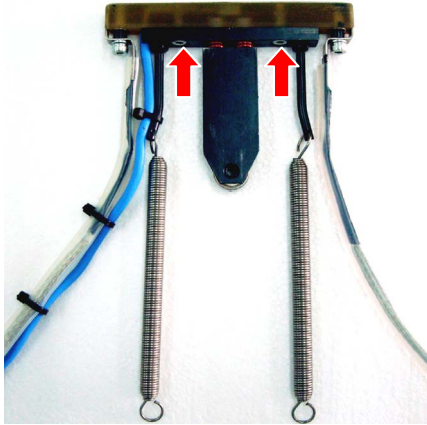

Heater assy

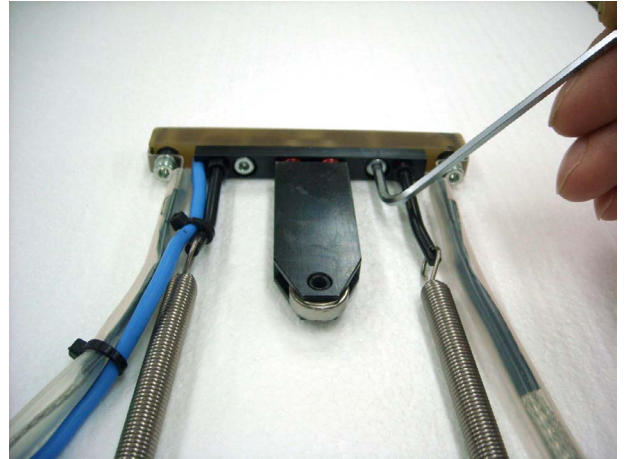

- 2) After dismounting the heater plate assy from the heater mounting plate, replace the heater plate assy.

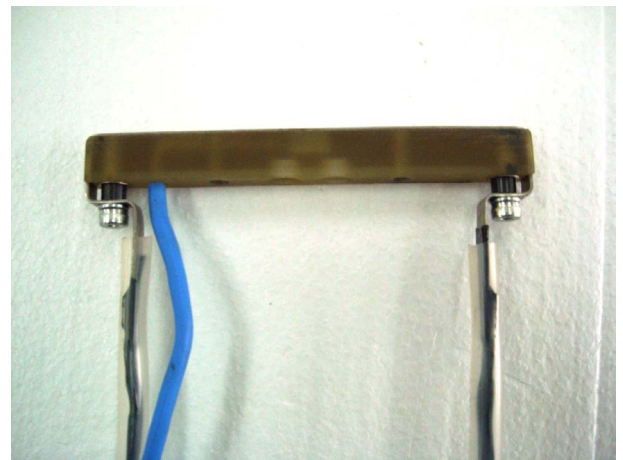
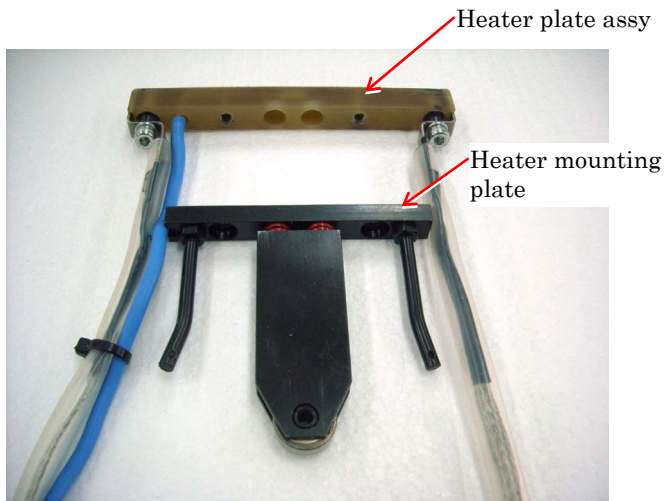

Heater plate assy

- * Remount the heater plate assy as it was fixed.

◆ Heater spring replacement

Dismount the heater assy from the banding unit before replacing the heater springs.
REF. Dismounting of heater assy (P.25)



Heater assy

- 1) Remove two bolts shown with arrows and dismount the heater plate assy.

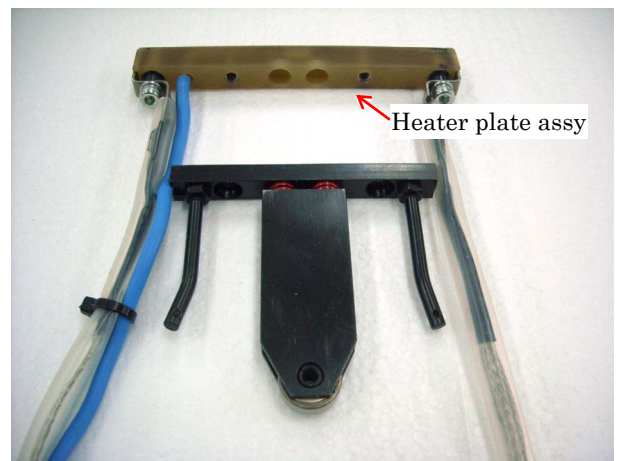
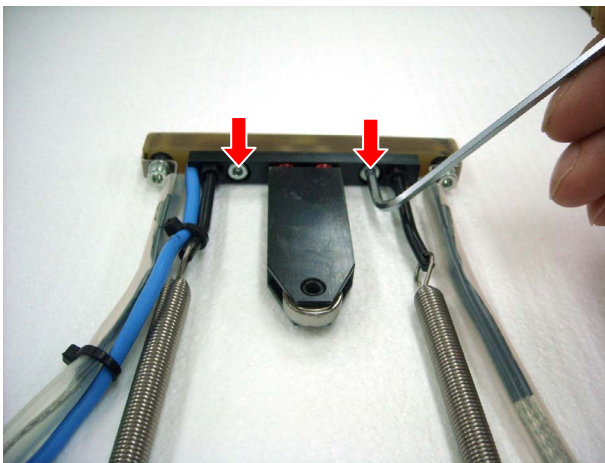

- 2) Loosen two set screws (locking screws) shown with arrow A at both sides of the slide plate and take out two bolts shown with arrows B from the slide plate.

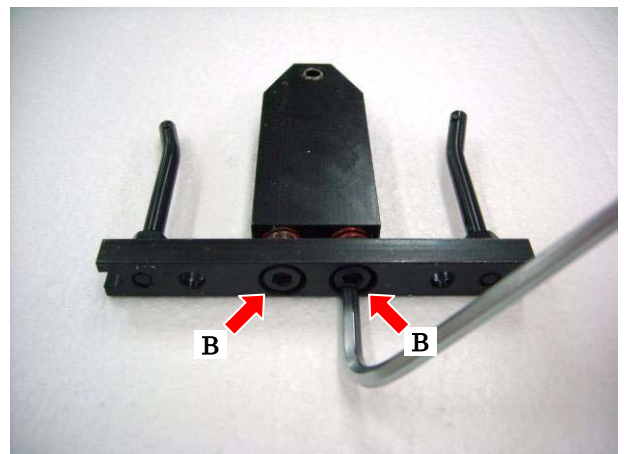
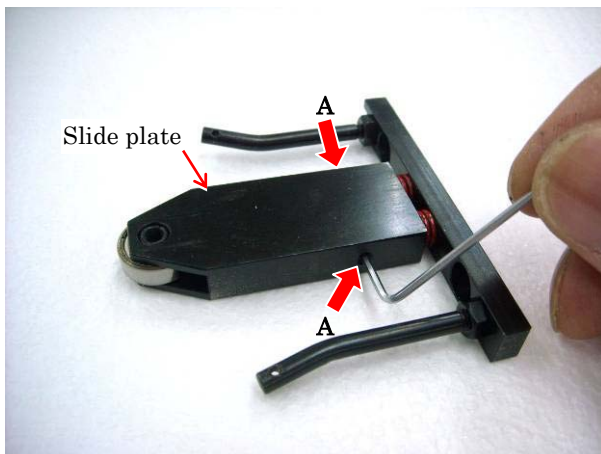

3) The heater springs can be replaced easily when the heater mounting plate is dismantled.

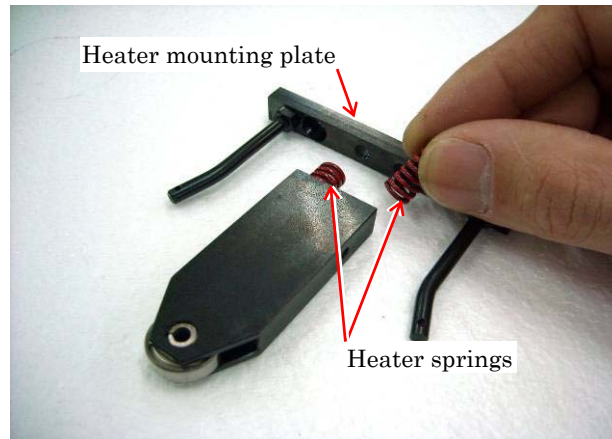

* Make sure these parts must be remounted as they were.
When fixing the heater mounting plate to the slide plate using bolts B, make sure there is a gap of 3 mm between the heater mounting plate and the slide plate upper surface. Then tighten the set screws A.

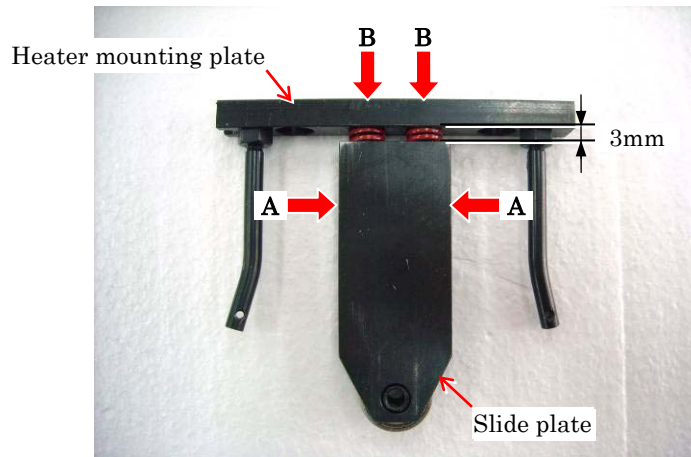

Rubber roller replacement

- 1) Dismount the front table, rear table, front machine cover and rear machine cover.
REF. Preparation for maintenance (P.13)
- 2) Remove the two bolts (shown with arrows) which are used to fix the roller shaft to the roller lever.
Dismount the roller shaft with the rubber roller.

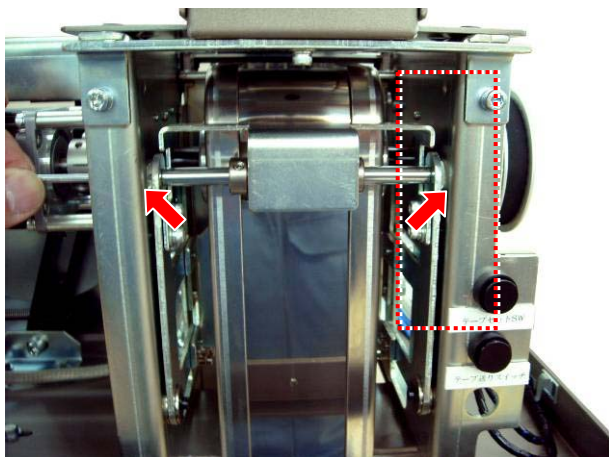

Left side of machine

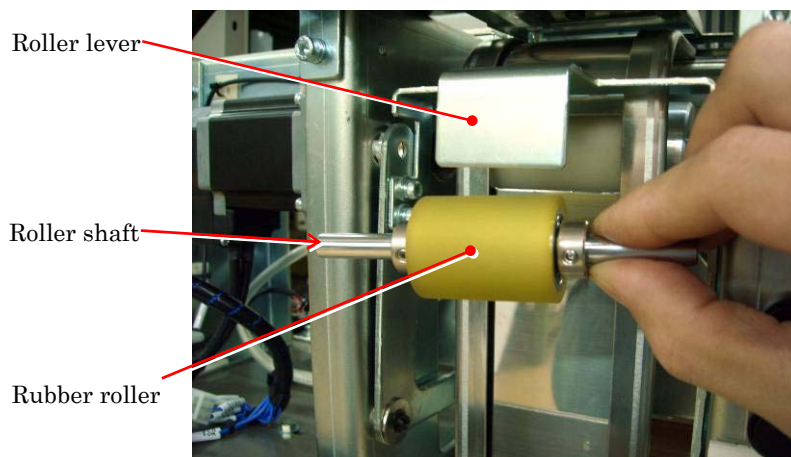
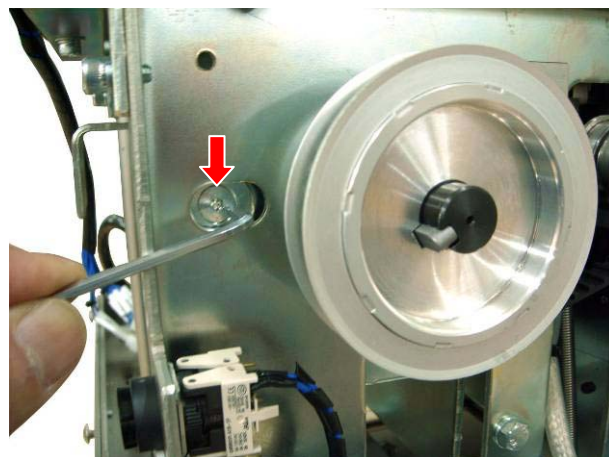

- 3) Loosen the two set screws (shown with arrows) at the either side of the rubber roller, dismount the the collar and then replace the rubber roller.

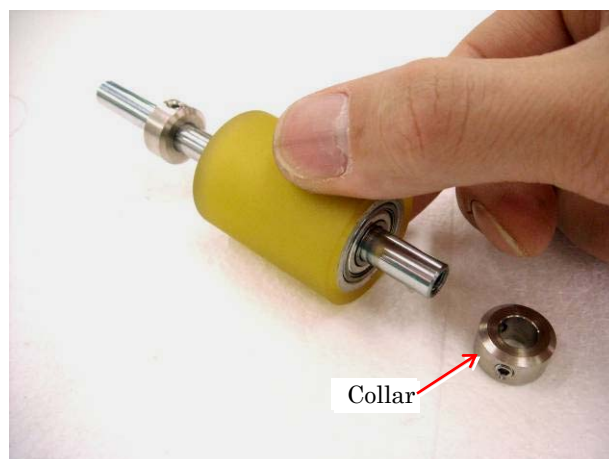
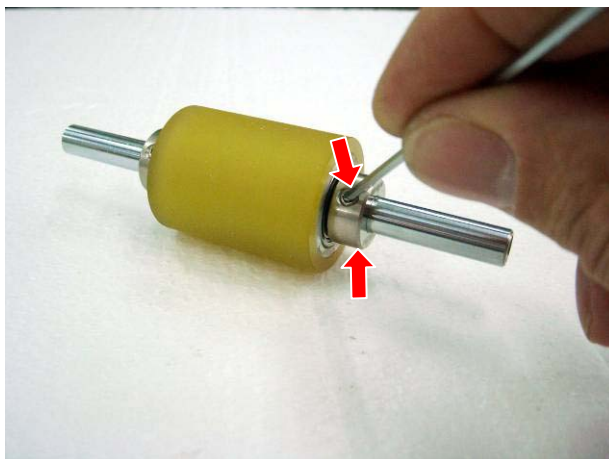

* Remount these parts as they were.

Slide plate spring replacement

Two pieces of the slide plate spring are used in the heater assy, right clamp assy, and cutter clamp assy. If one of these slide plate springs is damaged, dismantle the assy with this broken spring from the banding unit.

REF.: Dismounting of cutter clamp assy (P. 15)
Dismounting of heater assy (P. 25)
Dismounting of right clamp assy (P. 22)

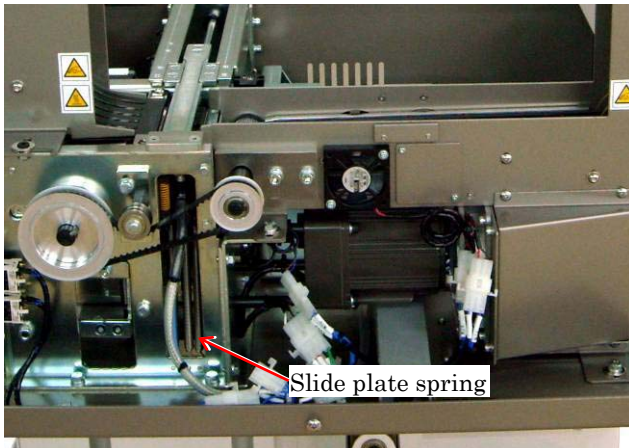

Front side of machine

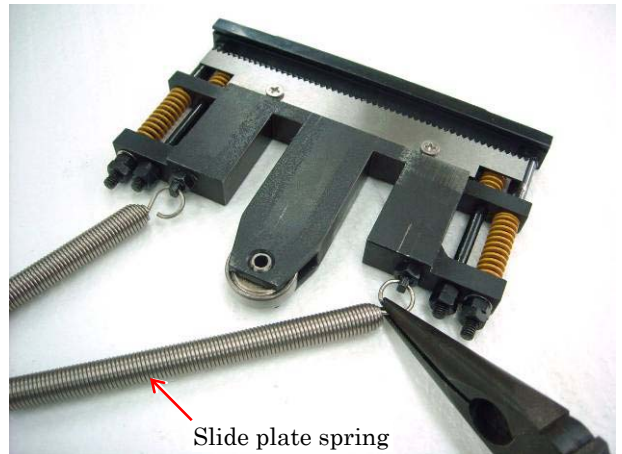

REF. Replacement of slide plate springs of cutter clamp assy

Roller spring replacement

- 1) Dismount the front table and front machine cover.
REF.: Preparation for maintenance (P. 13)
- 2) When you remove the nut shown with the arrow which is located at the left side bottom of the coil stand (upper), the roller spring can be replaced easily.

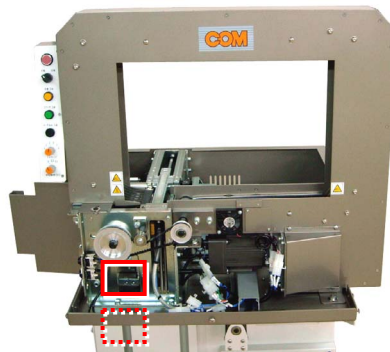

Front view of machine

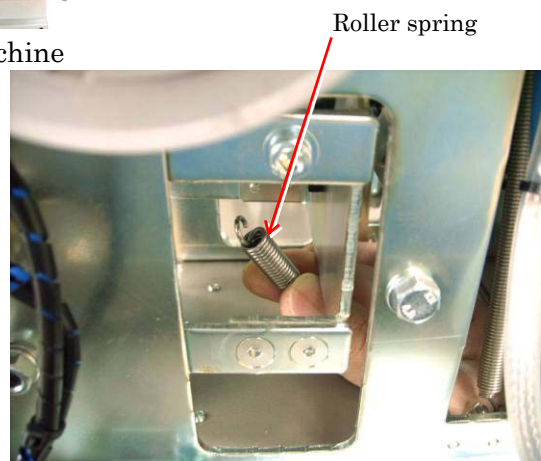
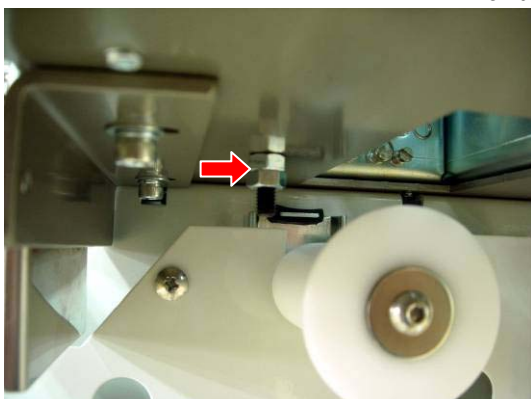

* Do not fail to remount these parts as they were.



TAIYO SEIKI CO.,LTD.

4-3-7, Hino, Daitoh, Osaka, 574-0062, Japan.

Phone: 81-72-873-3739 Fax: 81-72-875-4324

URL: <http://www.com-machine.co.jp>

E-mail: taiyo@com-machine.co.jp

PRINTED IN JAPAN

1-100416